

Steuergeraet
ELECTR. CONTROL UNIT (ECU)

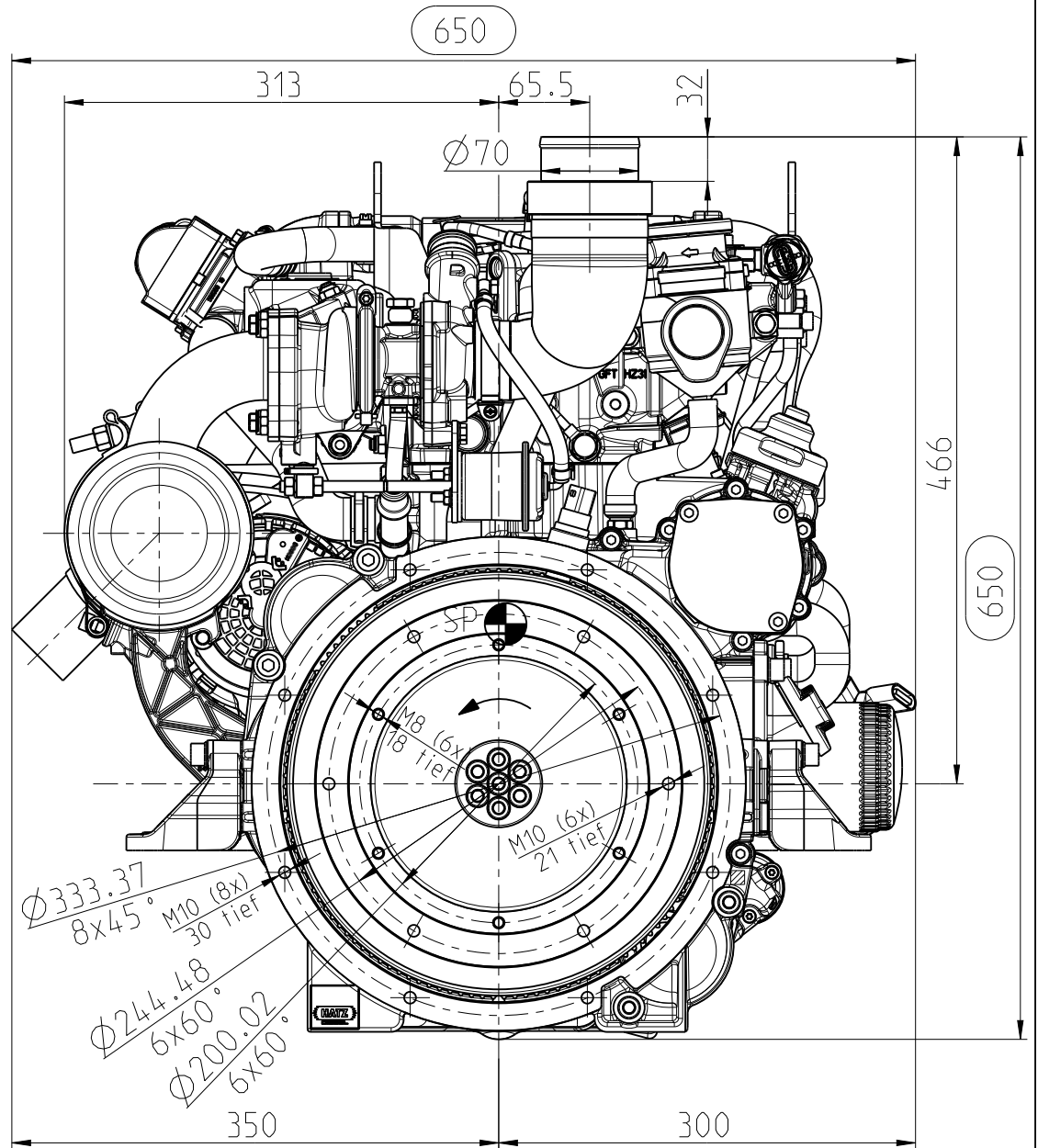

Aenderungen, die dem technischen Fortschritt dienen, behalten wir uns vor. / In the interests of technical progress we reserve the right to introduce modification
Toleranzbedingte Streubreite bei Kastenmaßen / The range of the length over-all based on tolerances can add up ±3mm

Nr.	Datum	Name	Änderung
NICHT MANUELL ÄNDERN			

Schutzvermerk nach
PROTECTION MARK ACC. TO
DIN ISO 16016



INSTALLATION DRAWING		MASSTAB	
EINBAUZEICHNUNG		SCALE	
3H50TIC - SAE 5 - F2F		1:5	
SHEET OF SHEETS		Schwungradseite	
Blatt 1 von 28		FLYWHEEL-SIDE	
Gez.	09.11.16	Mfi	Gepr. 09.11.16
		Gerh	

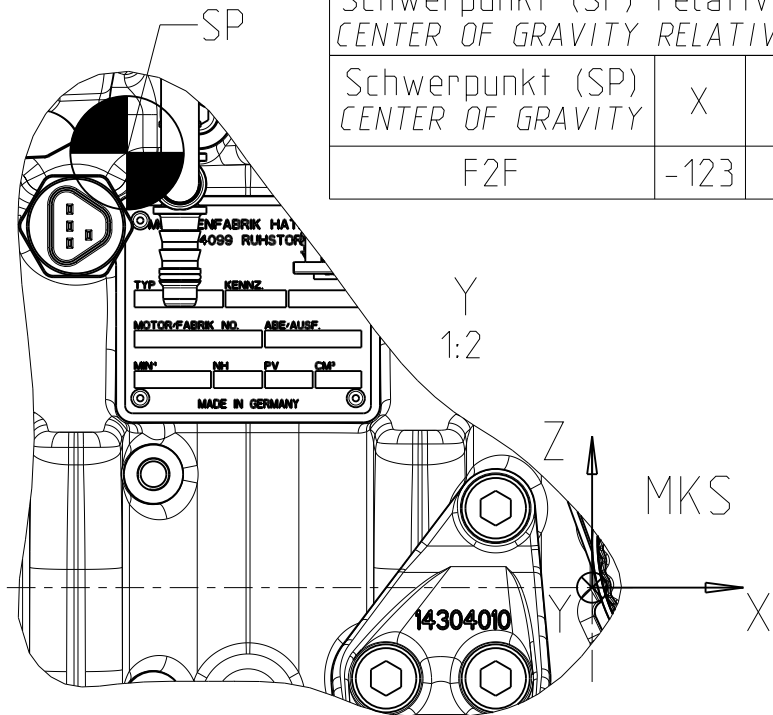

Schwerpunkt (SP) relativ zu MKS CENTER OF GRAVITY RELATIVE TO MKS			
Schwerpunkt (SP) CENTER OF GRAVITY	X	Y	Z
F2F	-123	-5	115

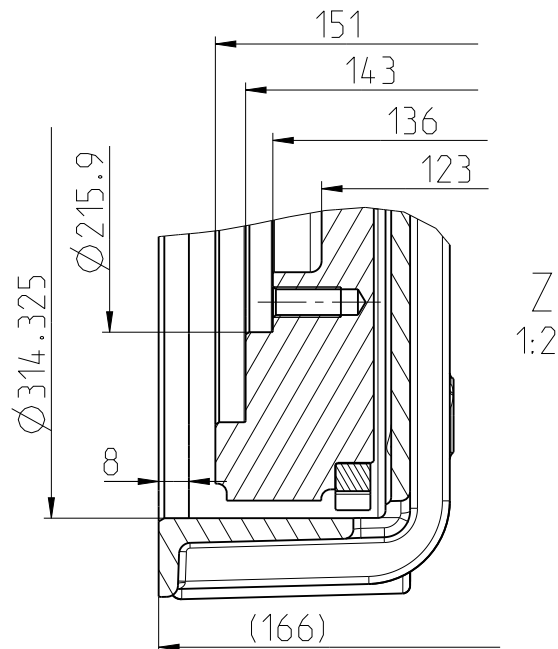
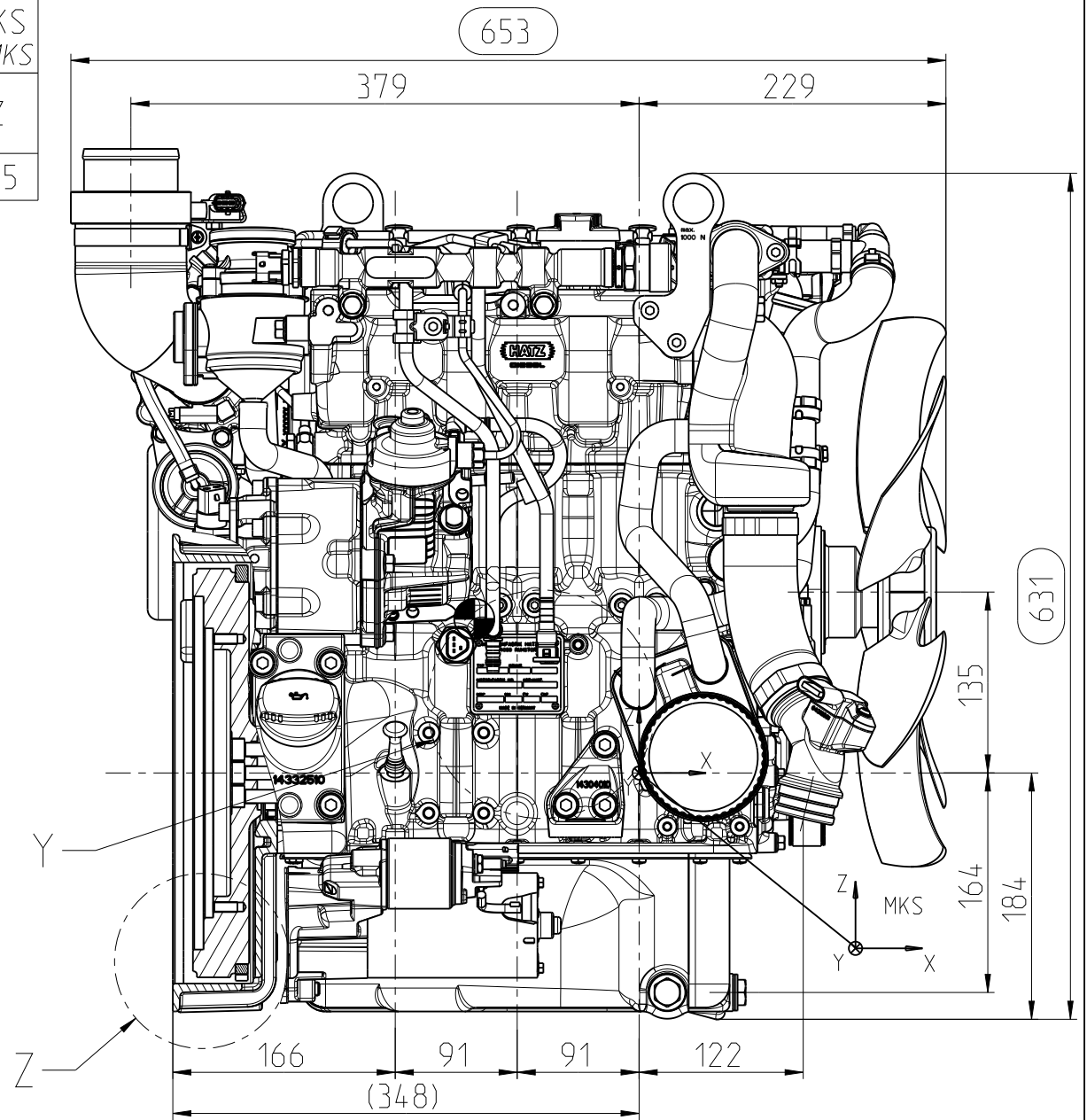

Nr.	Datum	Name	Änderung
NICHT MANUELL ÄNDERN			



INSTALLATION DRAWING
EINBAUZEICHNUNG
3H50TIC - SAE 5 - F2F

MASSTAB
SCALE
1:5(1:2)

SHEET OF SHEETS
Blatt 2 von 28

Bedienungsseite
OPERATOR-SIDE

Änderungen, die dem technischen Fortschritt dienen, behalten wir uns vor. / In the interests of technical progress we reserve the right to introduce modification
Toleranzbedingte Streubreite bei Kastenmaßen / The range of the length over-all based on tolerances can add up ±3mm

Schutzvermerk nach
PROTECTION MARK ACC. TO
DIN ISO 16016

Gez.	09.11.16	Mfi	Gepr.	09.11.16	Gerh
------	----------	-----	-------	----------	------

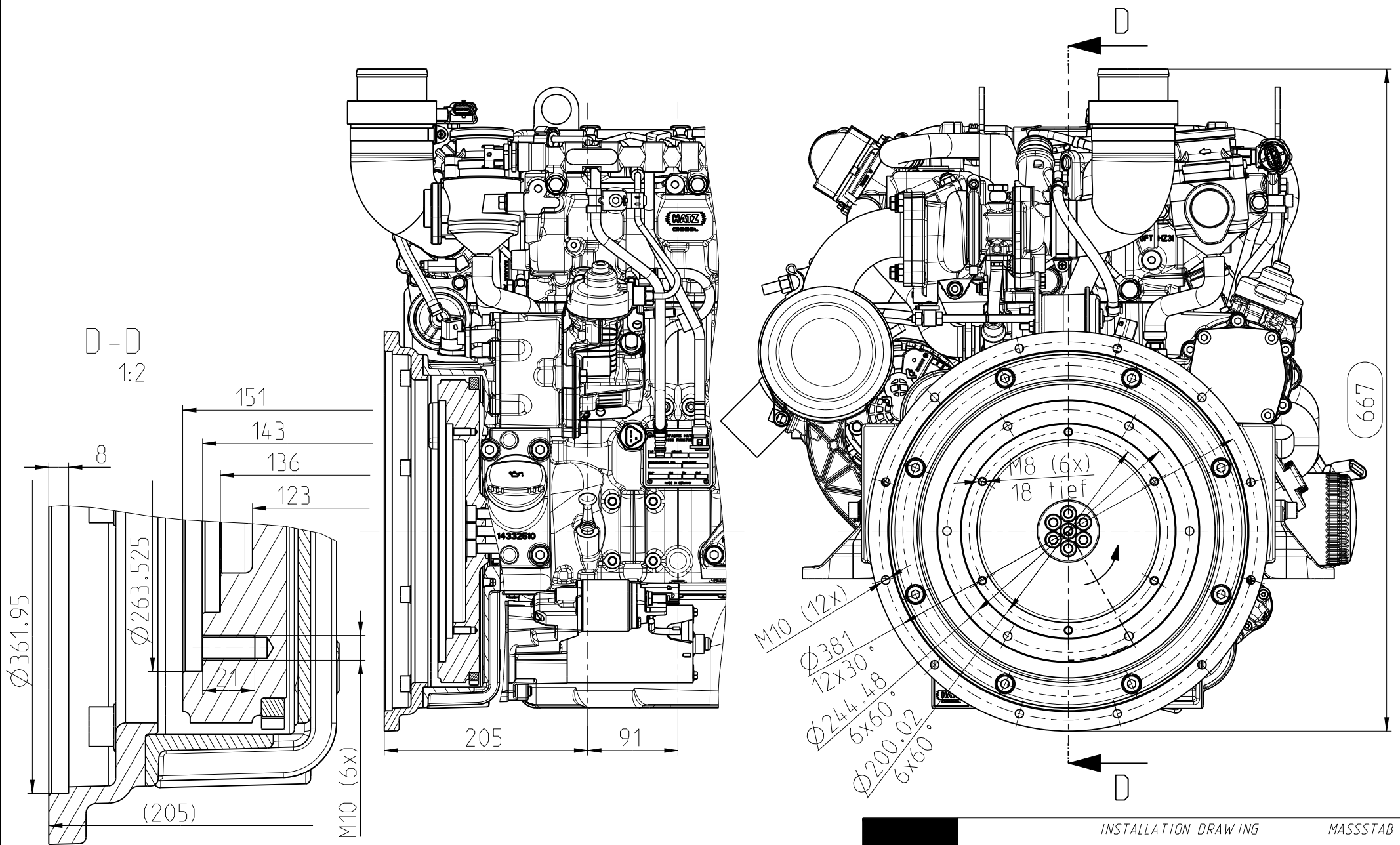

<table border="1" style="width: 100%; border-collapse: collapse;"> <thead> <tr> <th style="width: 10%;">Nr.</th> <th style="width: 15%;">Datum</th> <th style="width: 15%;">Name</th> <th style="width: 15%;">Änderung</th> </tr> </thead> <tbody> <tr> <td colspan="4" style="text-align: center;">NICHT MANUELL ÄNDERN</td> </tr> </tbody> </table>				Nr.	Datum	Name	Änderung	NICHT MANUELL ÄNDERN				<p>MOTORENFABRIK HATZ RUHSTORF-ROTT</p>	INSTALLATION DRAWING EINBAUZEICHNUNG 3H50TIC - SAE 4 - F2F	MASSSTAB SCALE 1:5(1:2)
Nr.	Datum	Name	Änderung											
NICHT MANUELL ÄNDERN														
Aenderungen, die dem technischen Fortschritt dienen, behalten wir uns vor. / In the interests of technical progress we reserve the right to introduce modification				SHEET OF SHEETS Blatt 3 von 28	Bedienungs- und Schwungradseite OPERATOR- AND FLYWHEEL-SIDE									
Toleranzbedingte Streubreite bei Kastenmaßen / The range of the length over-all based on tolerances can add up $\pm 3\text{mm}$				Schutzvermerk nach PROTECTION MARK ACC. TO DIN ISO 16016	Gez. 09.11.16 Mfi	Gepr. 09.11.16 Gerh								

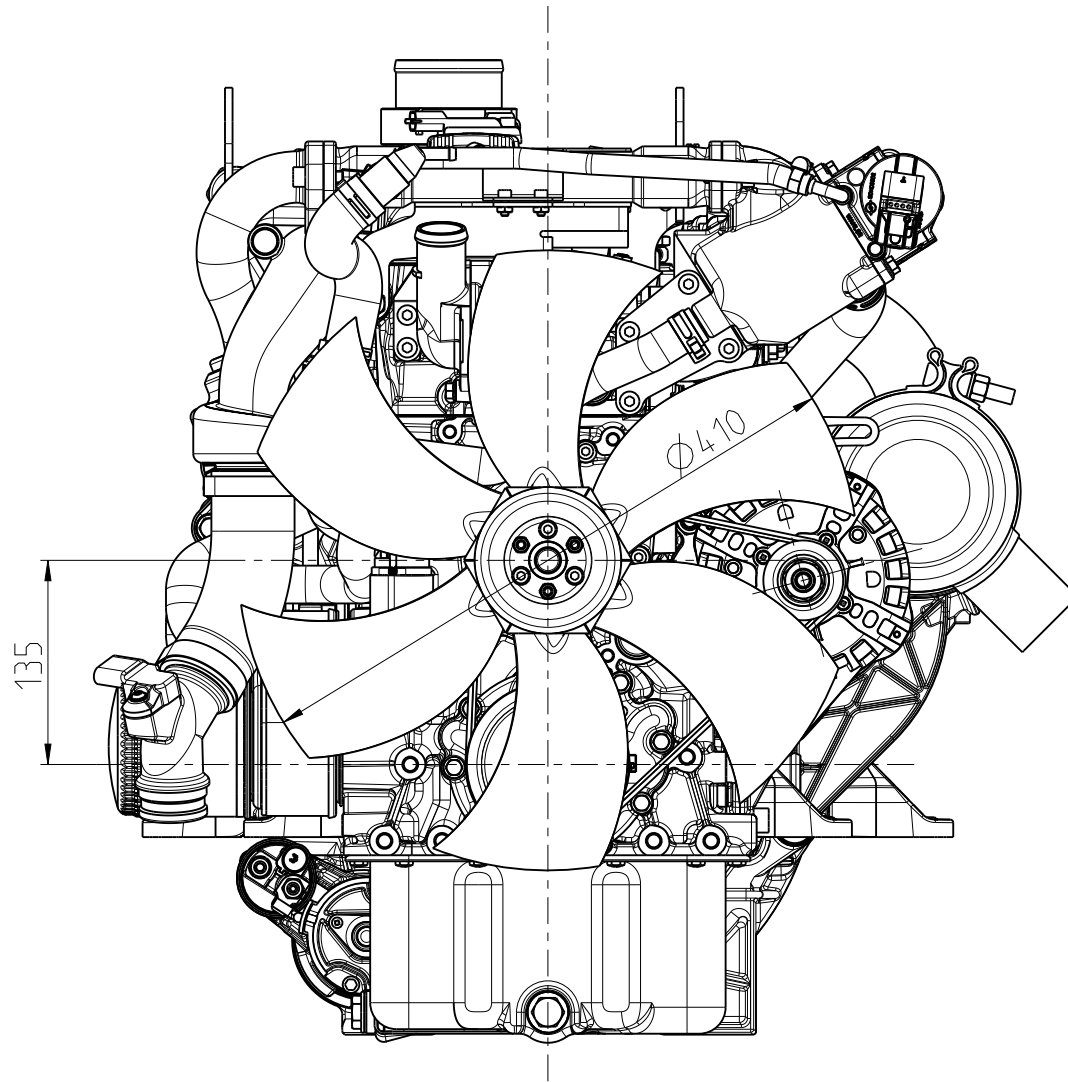

Nr.	Datum	Name	Änderung
NICHT MANUELL ÄNDERN			



INSTALLATION DRAWING

MASSTAB

EINBAUZEICHNUNG

SCALE

3H50TIC - F2F

1:5

SHEET OF SHEETS

Luefterseite

Blatt 4 von 28

FAN-SIDE

Aenderungen, die dem technischen Fortschritt dienen, behalten wir uns vor. / In the interests of technical progress we reserve the right to introduce modification

Schutzvermerk nach

DIN ISO 16016

Toleranzbedingte Streubreite bei Kastenmaßen / The range of the length over-all based on tolerances can add up ±3mm

PROTECTION MARK ACC. TO

Gez.	09.11.16	Mfi	Gepr.	09.11.16	Gerh
------	----------	-----	-------	----------	------

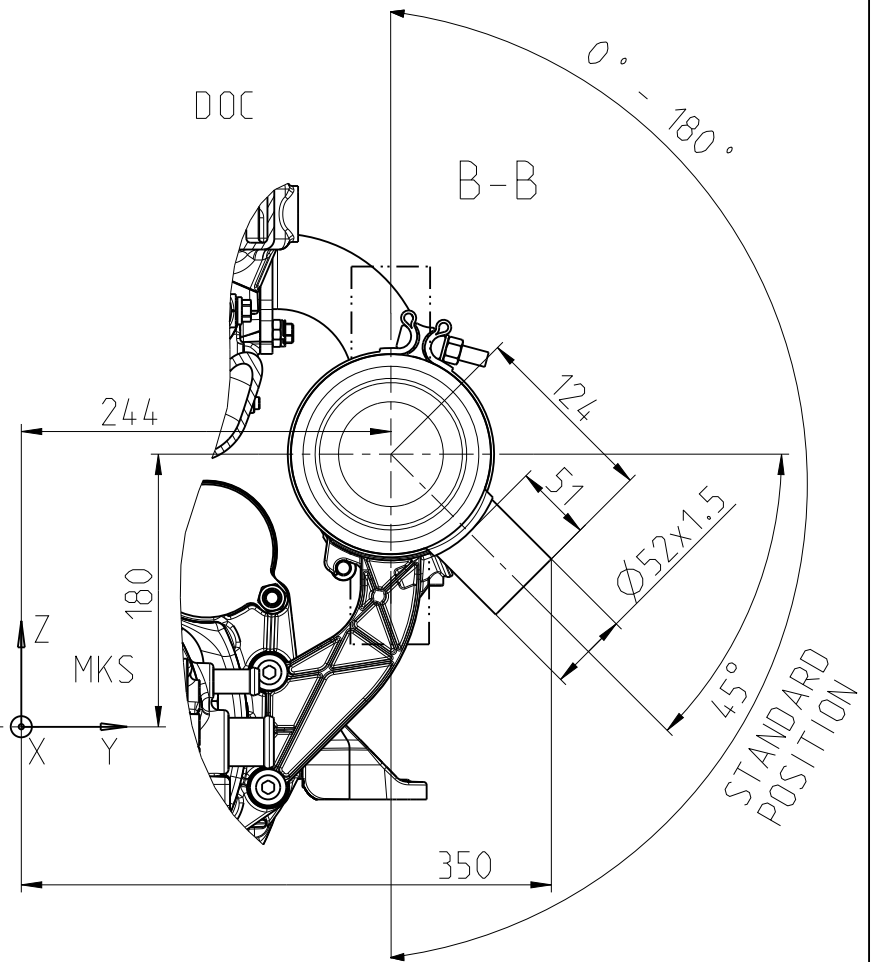
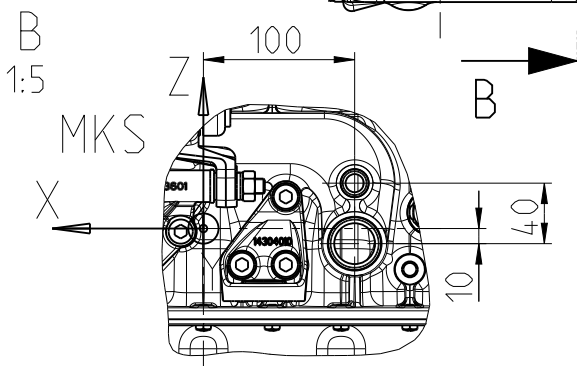
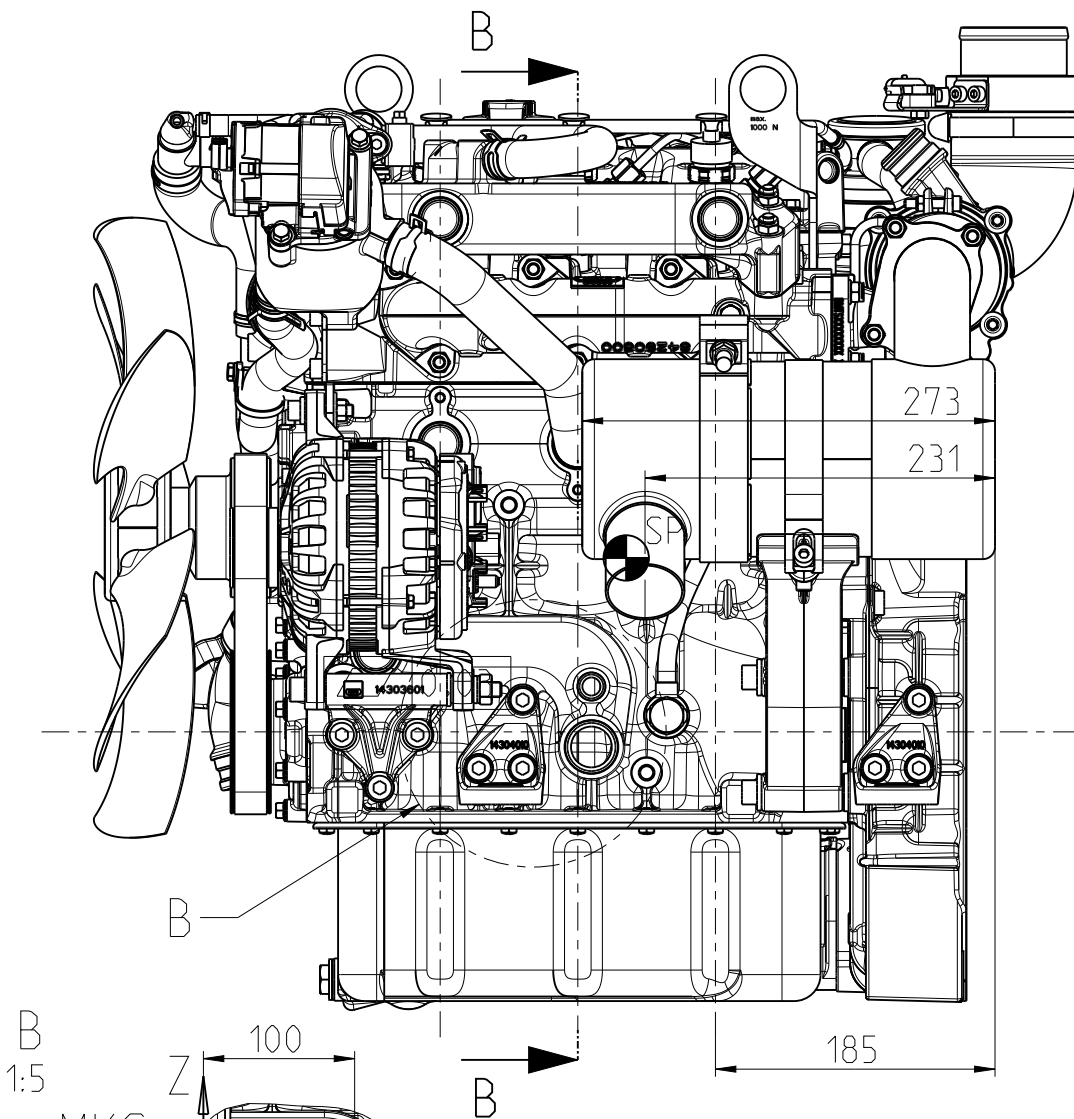

Nr.	Datum	Name	Änderung
NICHT MANUELL ÄNDERN			



INSTALLATION DRAWING

MASSTAB

EINBAUZEICHNUNG

SCALE

3H50TIC - F2F

1:5

SHEET OF SHEETS

Abgasseite

Blatt 5 von 28

EXHAUST GAS SIDE

Anderungen, die dem technischen Fortschritt dienen, behalten wir uns vor. / In the interests of technical progress we reserve the right to introduce modification

Schutzvermerk nach
PROTECTION MARK ACC. TO
DIN ISO 16016

Gez.	09.11.16	Mfi	Gepr.	09.11.16	Gerh
------	----------	-----	-------	----------	------

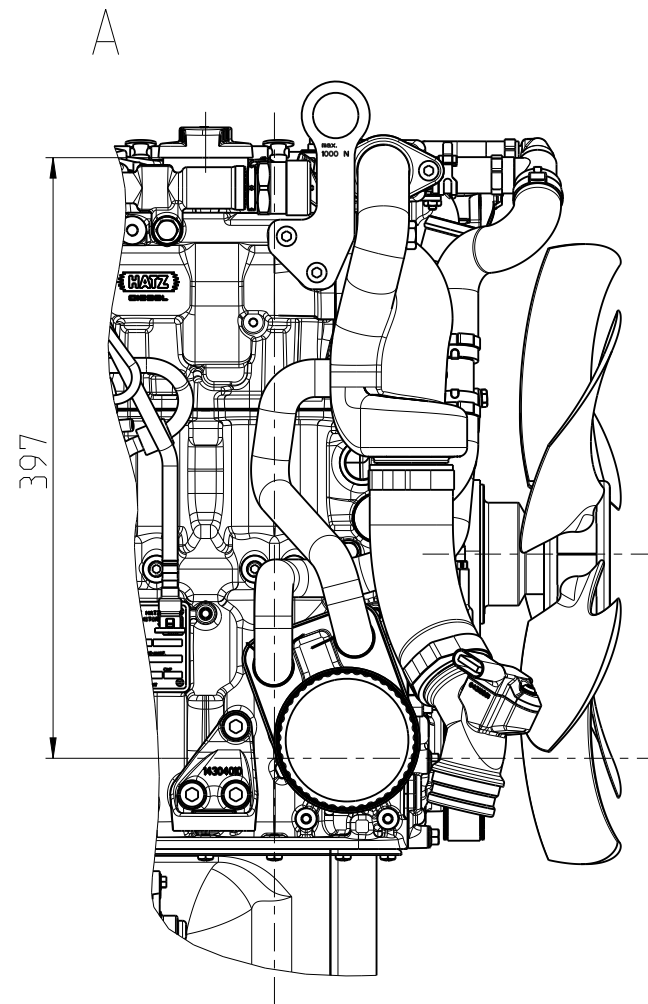
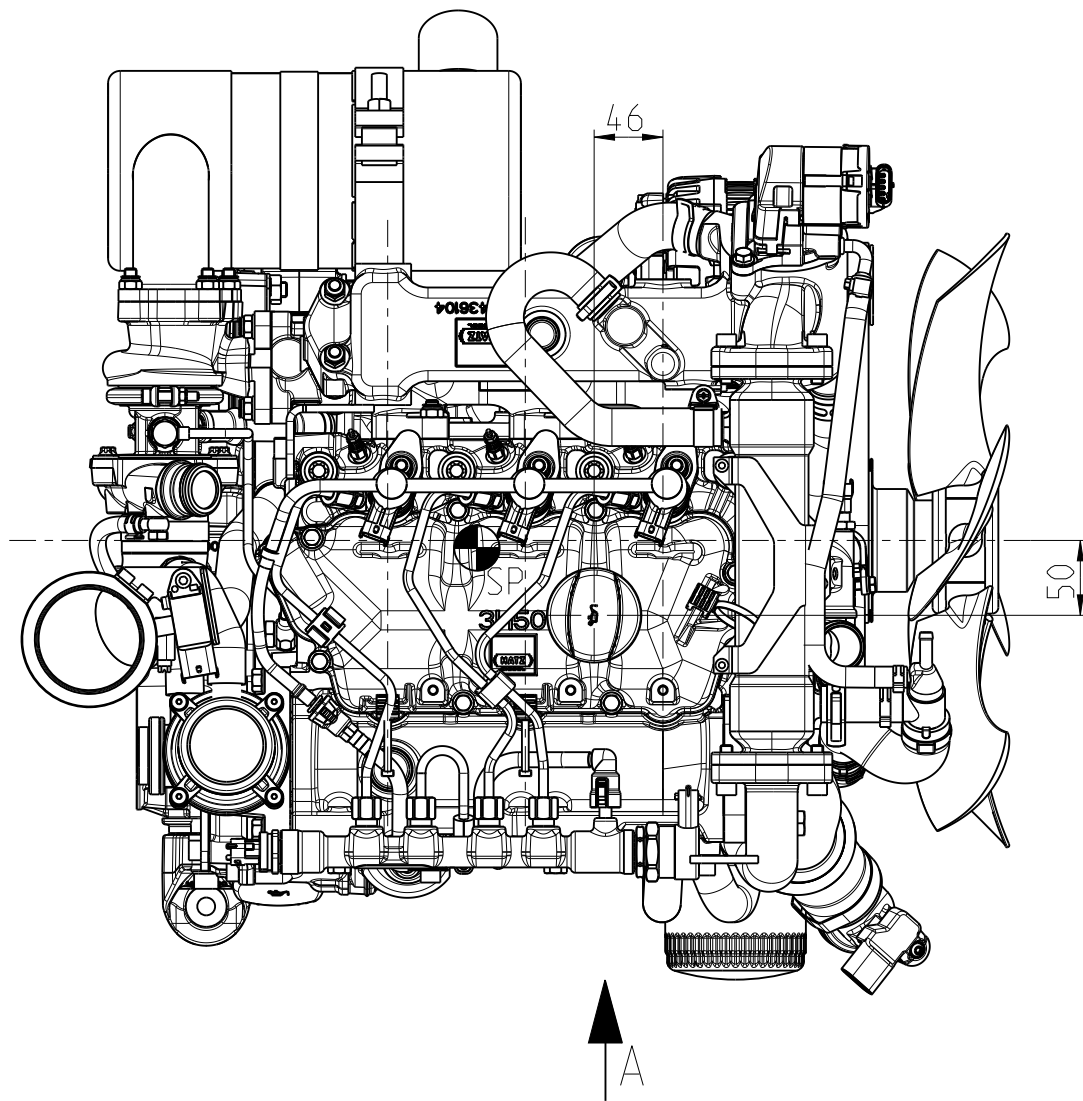

Aenderungen, die dem technischen Fortschritt dienen, behalten wir uns vor. / In the interests of technical progress we reserve the right to introduce modification

Nr.	Datum	Name	Änderung
NICHT MANUELL ÄNDERN			

Schutzvermerk nach
PROTECTION MARK ACC. TO
DIN ISO 16016



INSTALLATION DRAWING		MASSTAB	
EINBAUZEICHNUNG		SCALE	
3H50TIC - F2F		1:5	
SHEET OF SHEETS		Draufsicht	
Blatt 6 von 28		TOP-VIEW	
Gez.	09.11.16	Mfi	Gepr. 09.11.16
			Gerh

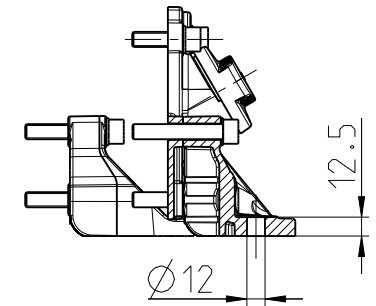
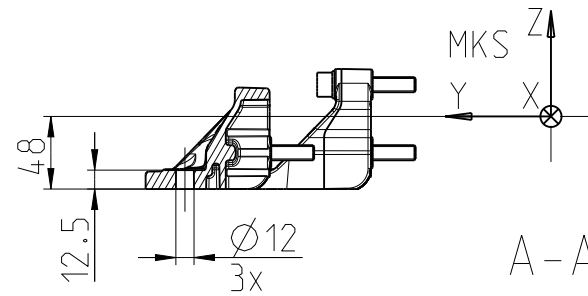
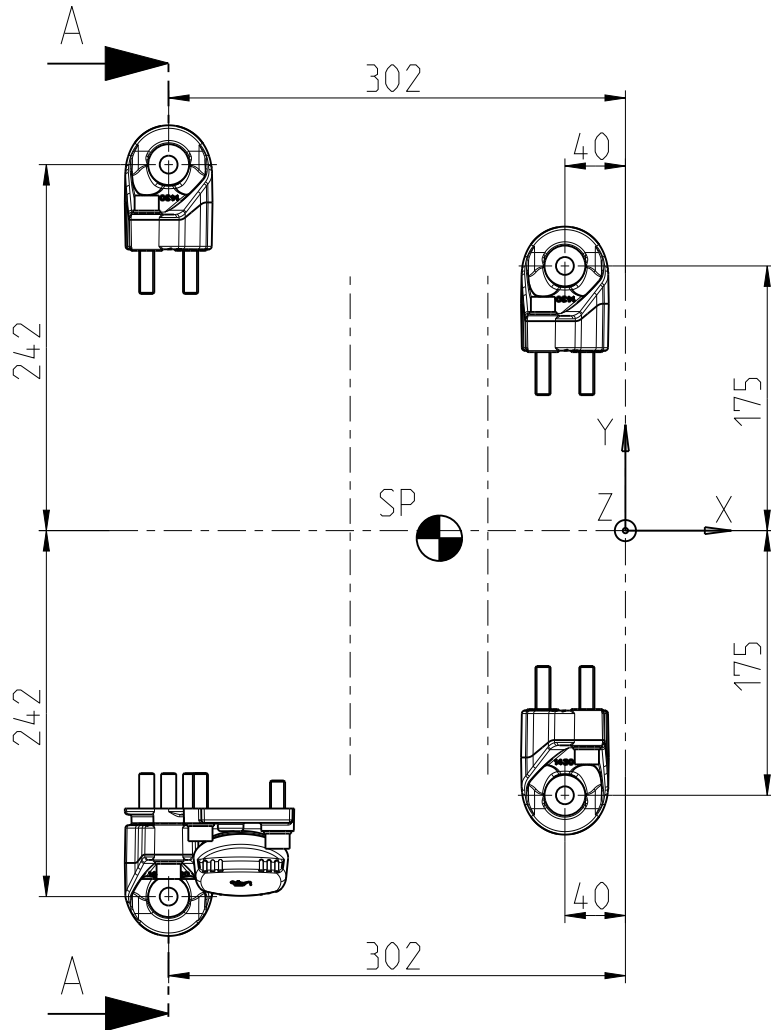
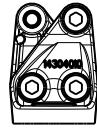
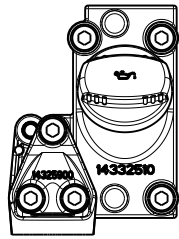

Aenderungen, die dem technischen Fortschritt dienen, behalten wir uns vor. / In the interests of technical progress we reserve the right to introduce modification
 Toleranzbedingte Streubreite bei Kastenmaßen / The range of the length over-all based on tolerances can add up ±3mm

Nr.	Datum	Name	Änderung
NICHT MANUELL ÄNDERN			
Schutzvermerk nach			DIN ISO 16016
PROTECTION MARK ACC. TO			



INSTALLATION DRAWING		MASSTAB	
EINBAUZEICHNUNG		SCALE	
3H50TIC - F2F		1:5	
SHEET OF SHEETS		Motorbefestigung	
Blatt 7 von 28		ENGINE MOUNTING	
Gez.	09.11.16	Mfi	Gerh
		Gepr.	09.11.16

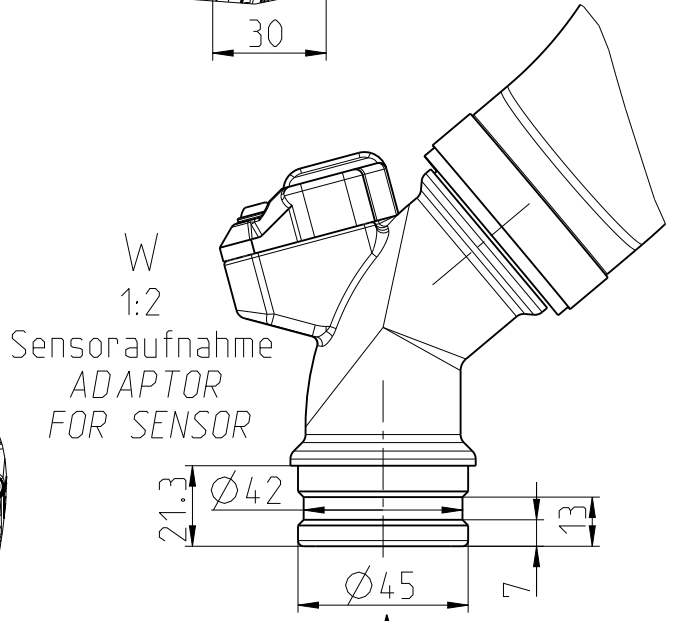
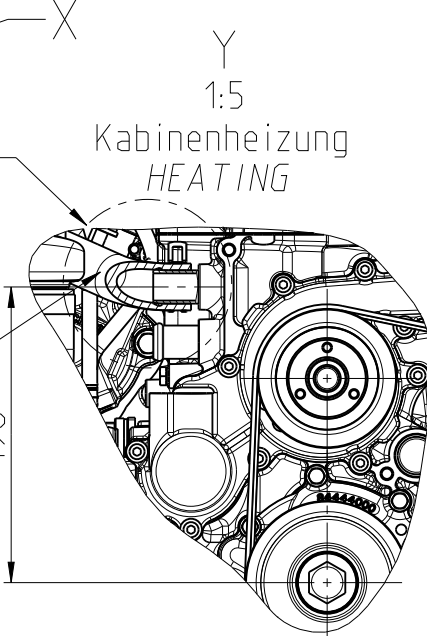
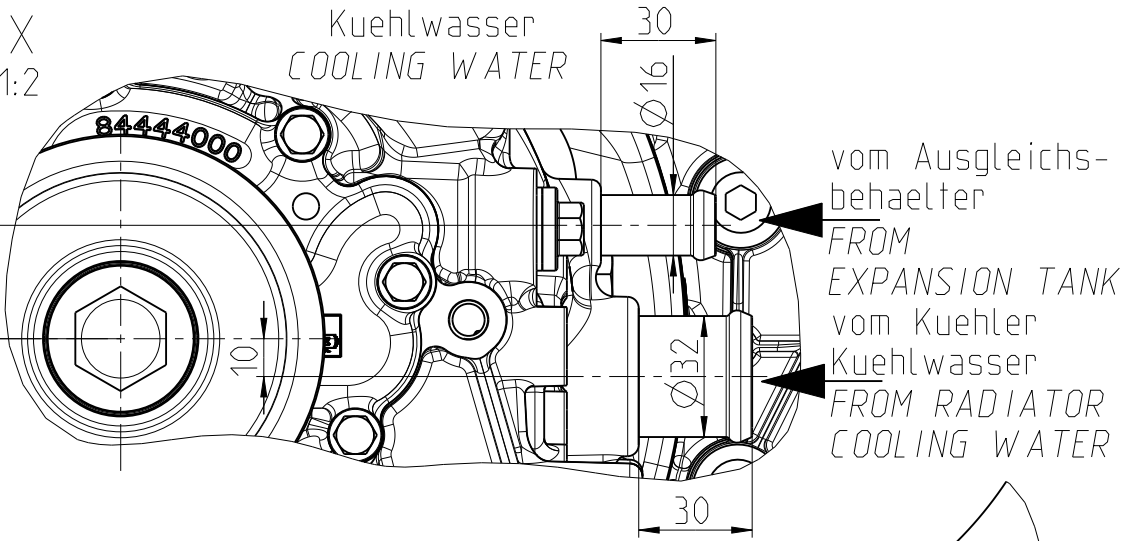
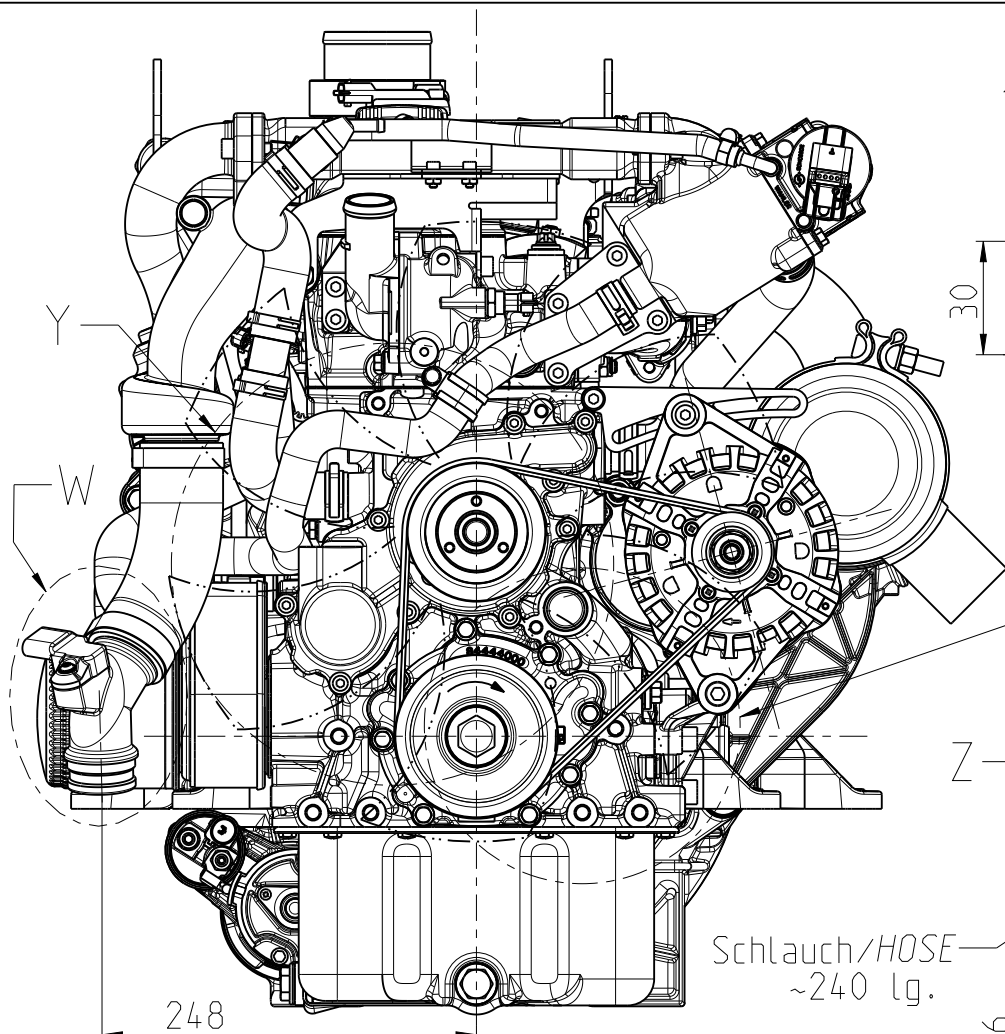

Schlauch/HOSE
~240 lg.

zur Kabinenheizung
TO THE HEATING

vom Kuehler
Ladeluft
FROM RADIATOR
BOOST AIR



Z
1:2

ohne Heizung
WITHOUT HEATING

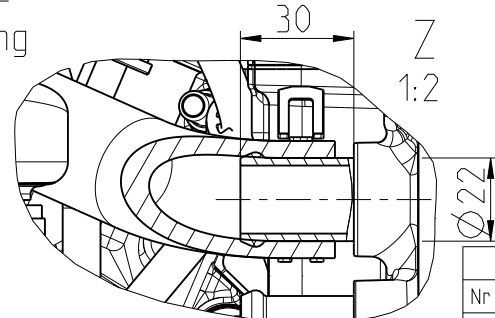

Nr.	Datum	Name	Änderung
NICHT MANUELL ÄNDERN			



INSTALLATION DRAWING		MASSTAB	
EINBAUZEICHNUNG		SCALE	
3H50TIC - F2F		1:5(1:2)	
Lufterseite ohne Lüfter FAN-SIDE WITHOUT FAN			
SHEET OF SHEETS		Blatt 8 von 28	
Gez.	09.11.16	Mfi	Gepr. 09.11.16
		Gerh	

Aenderungen, die dem technischen Fortschritt dienen, behalten wir uns vor. / In the interests of technical progress we reserve the right to introduce modification
Toleranzbedingte Streubreite bei Kastenmaßen / The range of the length over-all based on tolerances can add up ±3mm

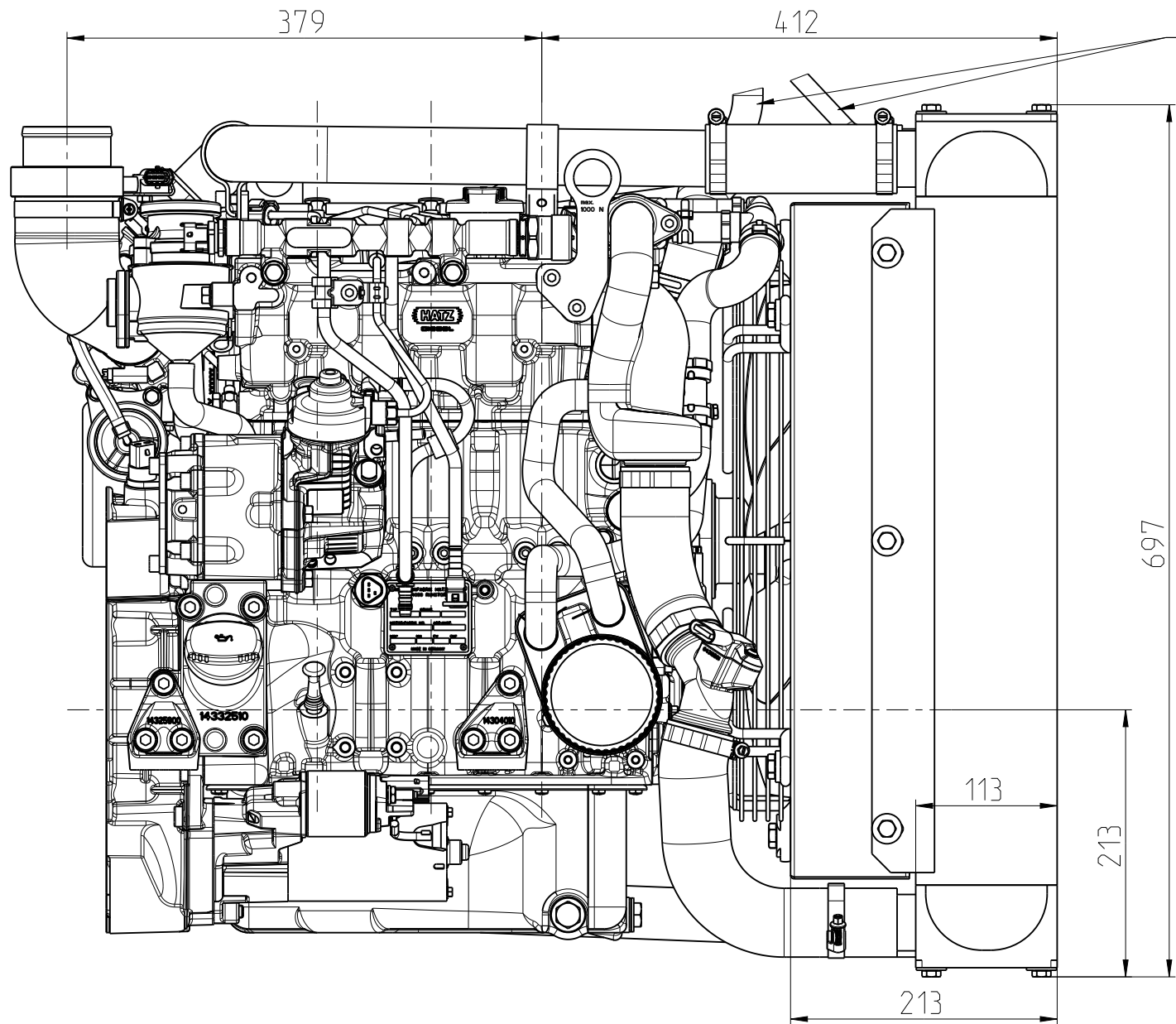

Zum Ausgleichsbehälter
TO EXPANSION TANK

Aenderungen, die dem technischen Fortschritt dienen, behalten wir uns vor. / In the interests of technical progress we reserve the right to introduce modification

Toleranzbedingte Streubreite bei Kastenmaßen / The range of the length over-all based on tolerances can add up $\pm 3\text{mm}$

Nr.	Datum	Name	Änderung
NICHT MANUELL ÄNDERN			
			Schutzvermerk nach PROTECTION MARK ACC. TO
			DIN ISO 16016



INSTALLATION DRAWING MASSSTAB
EINBAUZEICHNUNG SCALE
3H50TIC - F2F 1:5

SHEET OF SHEETS Bedienungsseite mit F2F Kombikuehler

Blatt 9 von 28 OPERATOR-SIDE WITH F2F RADIATOR AIR+WATER

Gez.	09.11.16	Mfi	Gepr.	09.11.16	Gerh
------	----------	-----	-------	----------	------

Zum Ausgleichsbehälter
TO EXPANSION TANK

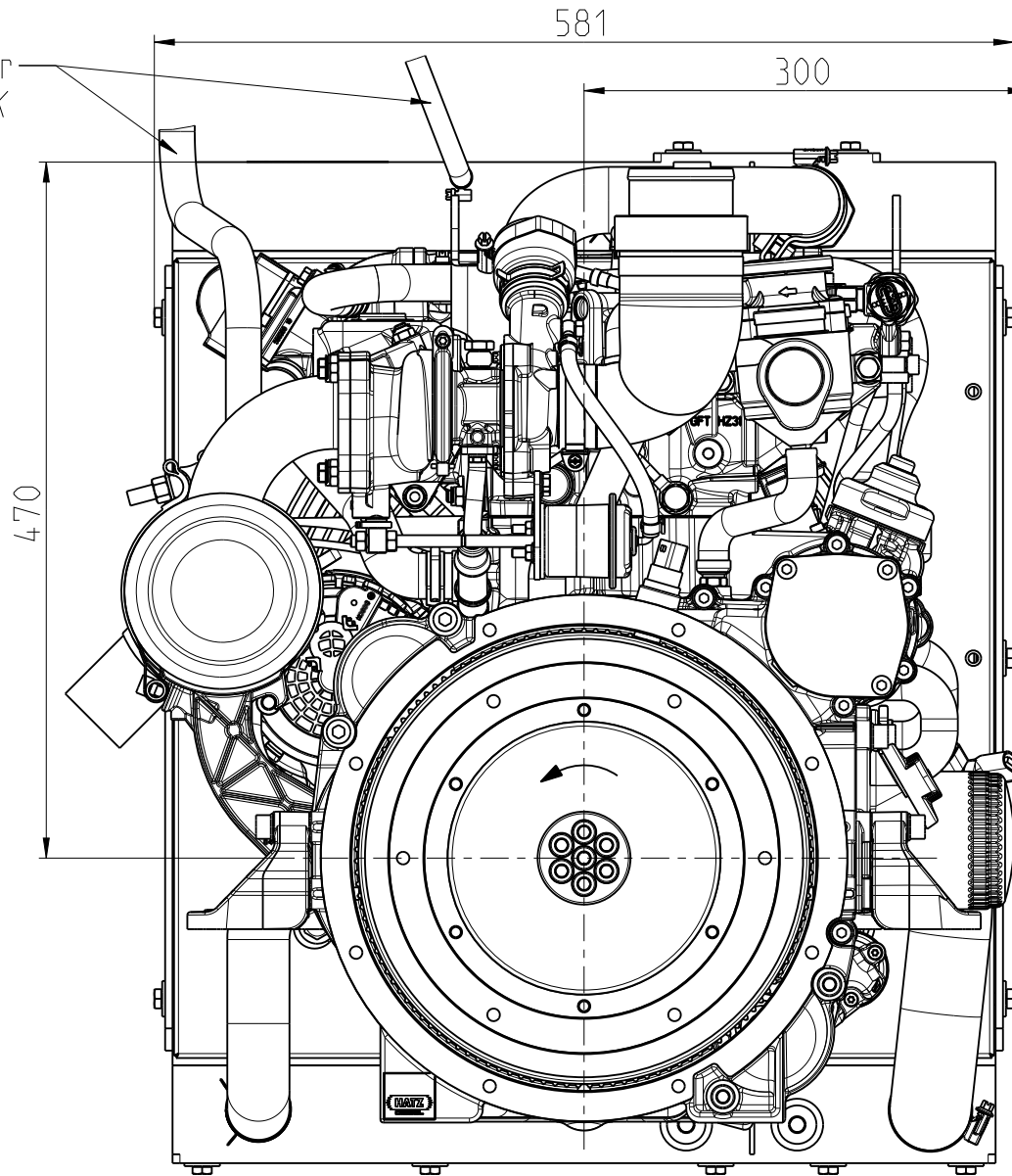

Nr.	Datum	Name	Änderung
NICHT MANUELL ÄNDERN			



MOTORENFABRIK
HATZ
RUHSTORF-ROTT

INSTALLATION DRAWING

MASSTAB

EINBAUZEICHNUNG

SCALE

3H50TIC - F2F

1:5

SHEET OF SHEETS

Schwungradseite mit F2F Kombiuehler

Blatt 10 von 28 FLYWHEEL-SIDE WITH F2F RADIATOR AIR+WATER

Änderungen, die dem technischen Fortschritt dienen, behalten wir uns vor. / In the interests of technical progress we reserve the right to introduce modification

Schutzvermerk nach

DIN ISO 16016

Toleranzbedingte Streubreite bei Kastenmaßen / The range of the length over-all based on tolerances can add up $\pm 3\text{mm}$

PROTECTION MARK ACC. TO

Gez.	09.11.16	Mfi	Gepr.	09.11.16	Gerh
------	----------	-----	-------	----------	------

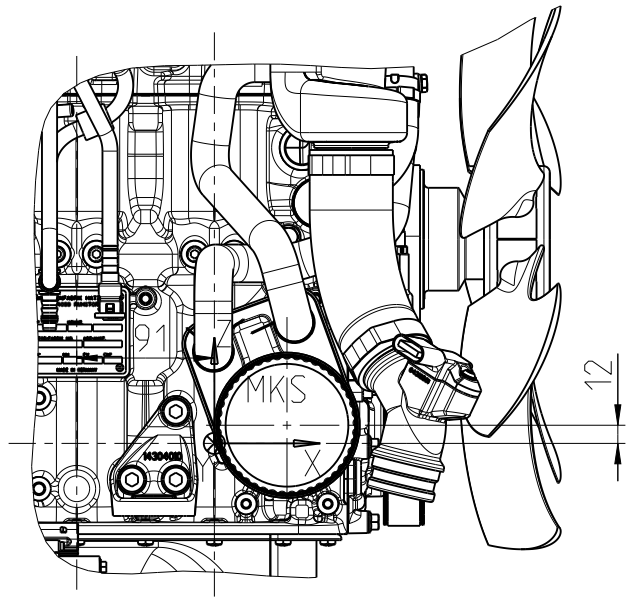

Oelfilter
horizontal
OILFILTER
HORIZONTAL

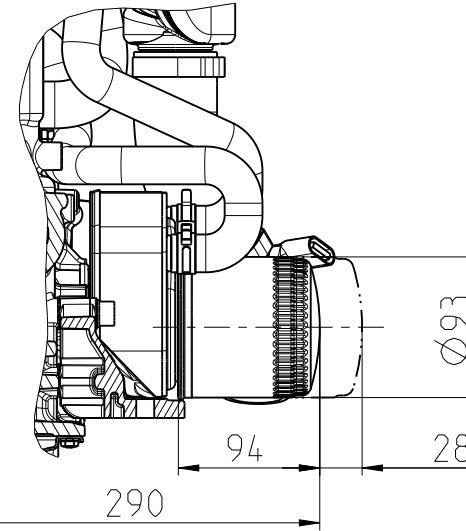
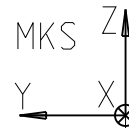

Oelfilter
vertikal
OILFILTER
VERTICAL

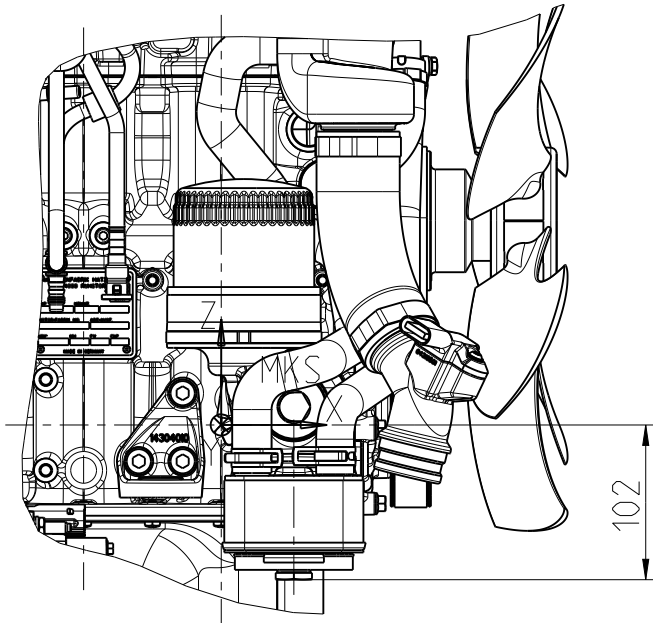
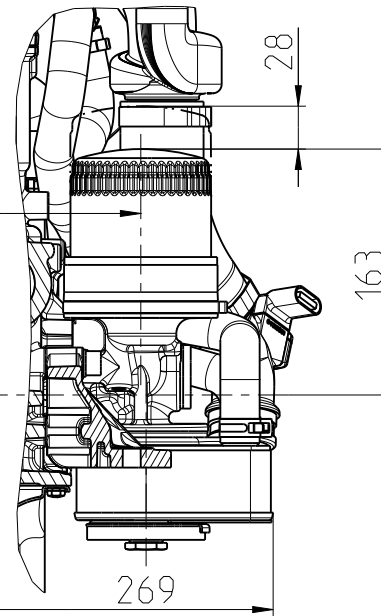
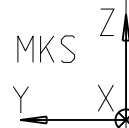

Aenderungen, die dem technischen Fortschritt dienen, behalten wir uns vor. / In the interests of technical progress we reserve the right to introduce modification
Toleranzbedingte Streubreite bei Kastenmaßen / The range of the length over-all based on tolerances can add up $\pm 3\text{mm}$

Nr.	Datum	Name	Änderung
NICHT MANUELL ÄNDERN			

Schutzvermerk nach
PROTECTION MARK ACC. TO
DIN ISO 16016



SHEET OF SHEETS
Blatt 11 von 28

Gez. 09.11.16 Mfi Gepr. 09.11.16 Gerh

INSTALLATION DRAWING MASSSTAB

EINBAUZEICHNUNG SCALE

3H50TIC 1:5

Oelfilter-vert/hori

OILFILTER-VERT/HORI

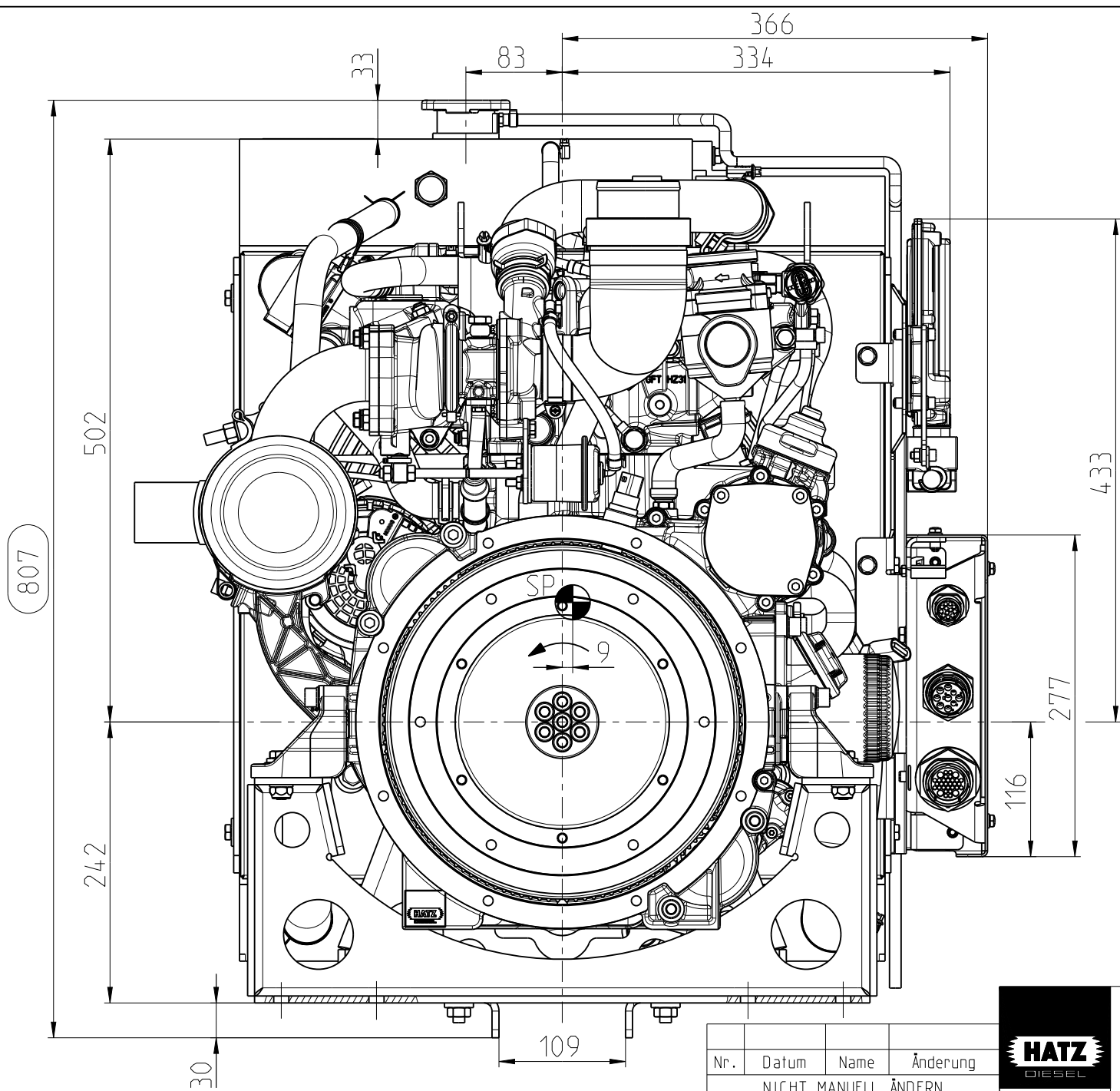

807



Nr.	Datum	Name	Änderung
NICHT MANUELL ÄNDERN			

INSTALLATION DRAWING MASSSTAB
EINBAUZEICHNUNG SCALE
3H50TIC - OPU 1:5

SHEET OF SHEETS		Schwungradseite	
Blatt 12 von 28		FLYWHEEL-SIDE	
Gez.	09.11.16	Mfi	Gepr. 09.11.16
		Gerh	

Aenderungen, die dem technischen Fortschritt dienen, behalten wir uns vor. / In the interests of technical progress we reserve the right to introduce modification
Toleranzbedingte Streubreite bei Kastenmaßen / The range of the length over-all based on tolerances can add up ±3mm

Schutzvermerk nach
PROTECTION MARK ACC. TO
DIN ISO 16016

466

242

322

777

412

836

Schwerpunkt (SP) relativ zu MKS
CENTER OF GRAVITY RELATIVE TO MKS

Schwerpunkt (SP)
ohne Betriebsstoffe
CENTER OF GRAVITY
WITHOUT OPERATING FLUIDS

Schwerpunkt (SP) CENTER OF GRAVITY	X	Y	Z
OPU	-3	-9	103

Nr.	Datum	Name	Änderung
NICHT MANUELL ÄNDERN			



INSTALLATION DRAWING MASSTAB

EINBAUZEICHNUNG SCALE

3H50TIC - OPU 1:5

SHEET OF SHEETS

Blatt 13 von 28

Bedienungsseite

OPERATOR-SIDE

Änderungen, die dem technischen Fortschritt dienen, behalten wir uns vor. / In the interests of technical progress we reserve the right to introduce modification

Schutzvermerk nach
PROTECTION MARK ACC. TO
DIN ISO 16016

Gez.	09.11.16	Mfi	Gepr.	09.11.16	Gerh
------	----------	-----	-------	----------	------

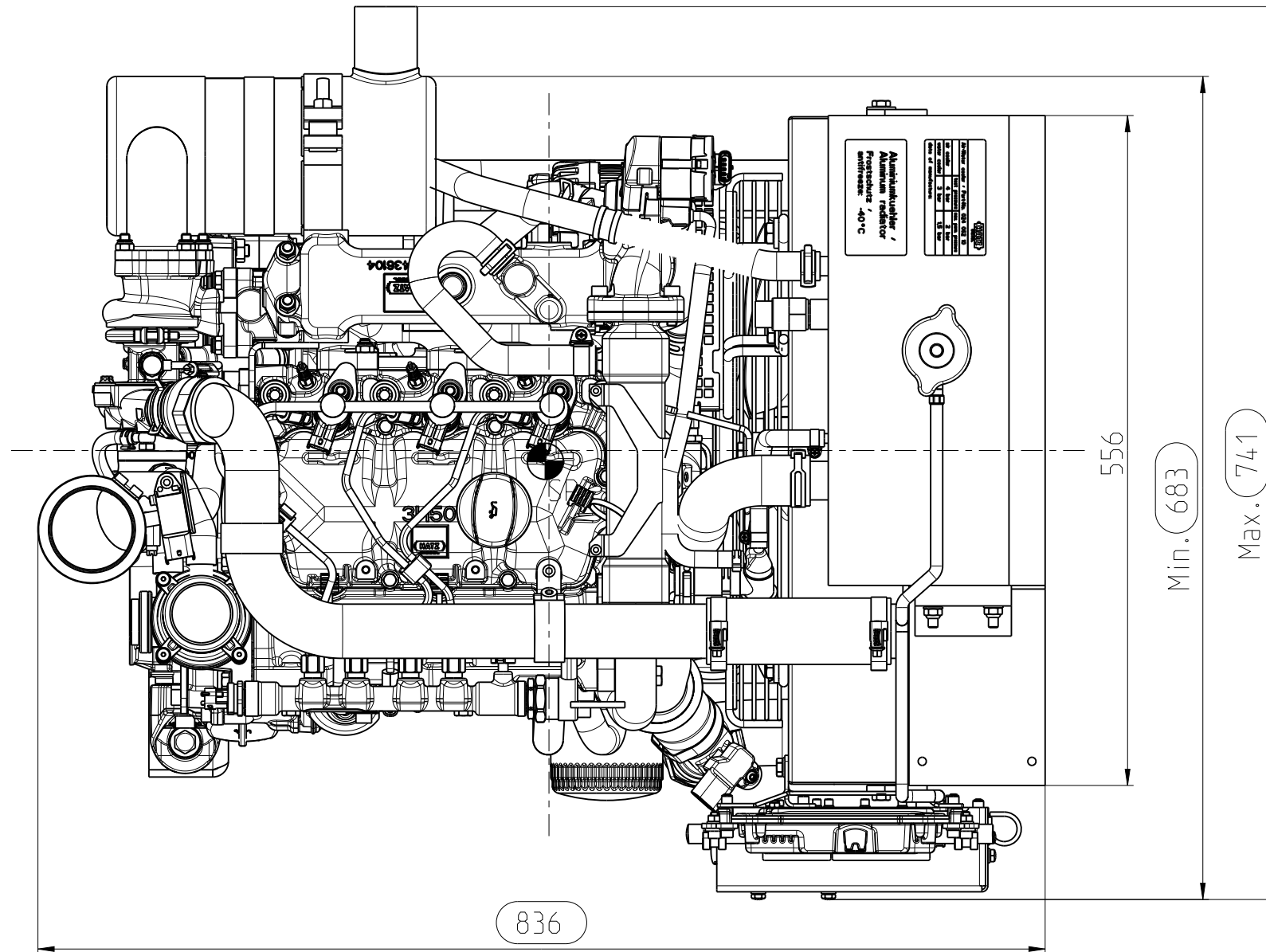

Nr.	Datum	Name	Änderung
NICHT MANUELL ÄNDERN			



INSTALLATION DRAWING

MASSTAB

EINBAUZEICHNUNG

SCALE

3H50TIC - OPU

1:5

SHEET OF SHEETS

Draufsicht

Blatt 14 von 28

TOP-VIEW

Aenderungen, die dem technischen Fortschritt dienen, behalten wir uns vor. / In the interests of technical progress we reserve the right to introduce modification

Schutzvermerk nach
PROTECTION MARK ACC. TO

DIN ISO 16016

Gez.

09.11.16

Mfi

Gepr.

09.11.16

Gerh

Toleranzbedingte Streubreite bei Kastenmaßen / The range of the length over-all based on tolerances can add up $\pm 3\text{mm}$

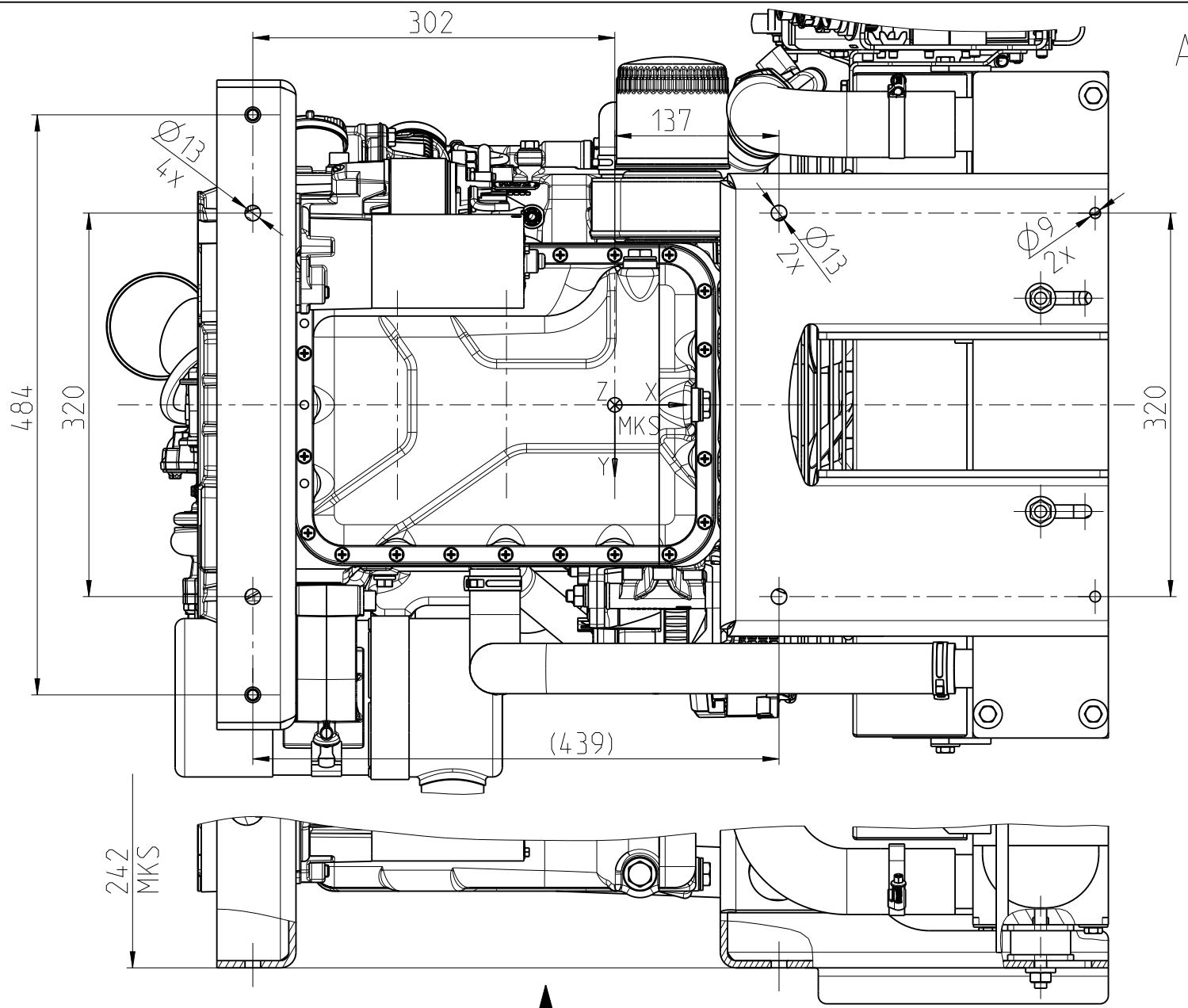

Nr.	Datum	Name	Änderung
NICHT MANUELL ÄNDERN			
			Schutzvermerk nach PROTECTION MARK ACC. TO
			DIN ISO 16016



INSTALLATION DRAWING MASSSTAB
 EINBAUZEICHNUNG SCALE
 3H50TIC - OPU 1:5
 Motorbefestigung OPU
 ENGINE MOUNTING OPU
 SHEET OF SHEETS
 Blatt 15 von 28
 Gez. 09.11.16 Mfi Gepr. 09.11.16 Gerh

Änderungen, die dem technischen Fortschritt dienen, behalten wir uns vor. / In the interests of technical progress we reserve the right to introduce modification
 Toleranzbedingte Streubreite bei Kastenmaßen / The range of the length over-all based on tolerances can add up ±3mm

Adapter Ladeluft
 f. kundenseitige Verrohrung
 ADAPTER BOOST AIR
 F. CUSTOMIZED PIPEWORK

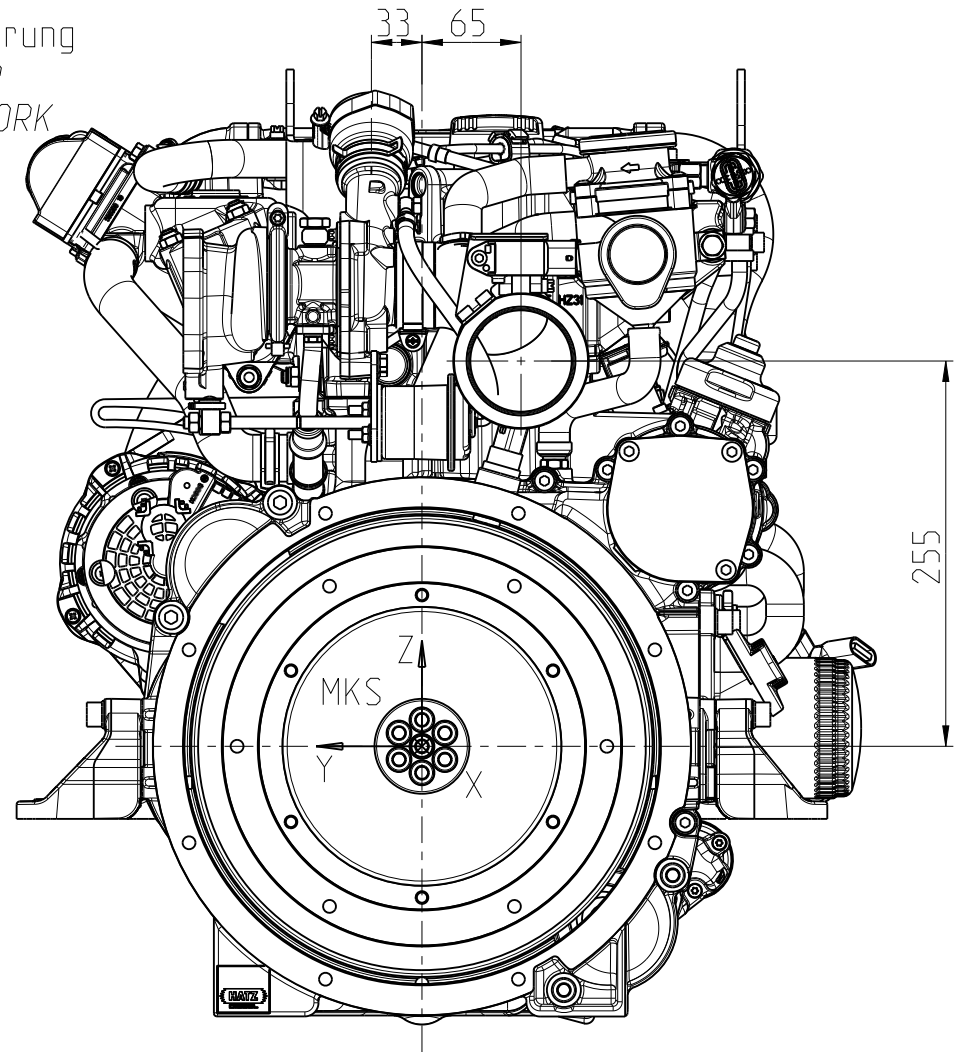
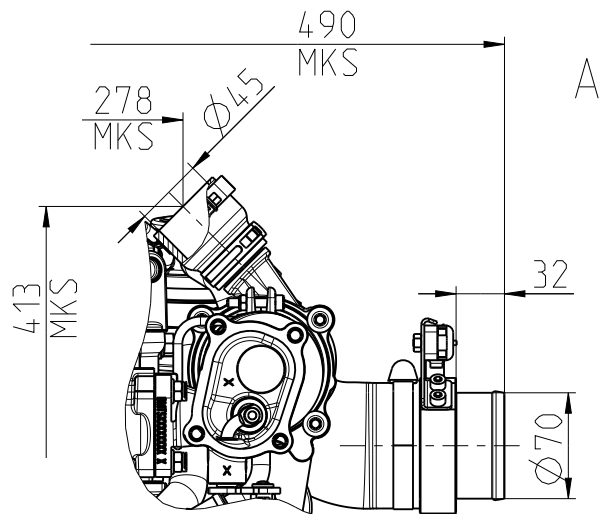
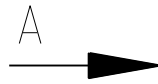

Aenderungen, die dem technischen Fortschritt dienen, behalten wir uns vor. / In the interests of technical progress we reserve the right to introduce modification

Nr.	Datum	Name	Änderung
NICHT MANUELL ÄNDERN			

Schutzvermerk nach
 PROTECTION MARK ACC. TO
 DIN ISO 16016



INSTALLATION DRAWING
 EINBAUZEICHNUNG
 3H50TIC - F2F
 SHEET OF SHEETS
 Blatt 16 von 28
 Gez. 09.11.16 Mfi Gepr. 09.11.16 Gerh
 MASSTAB
 SCALE
 1:5
 Turbo 45° - Luftansaugung horiz.
 TURBO 45° - AIR SUCTION HORIZ.

Toleranzbedingte Streubreite bei Kastenmaßen / The range of the length over-all based on tolerances can add up ±3mm

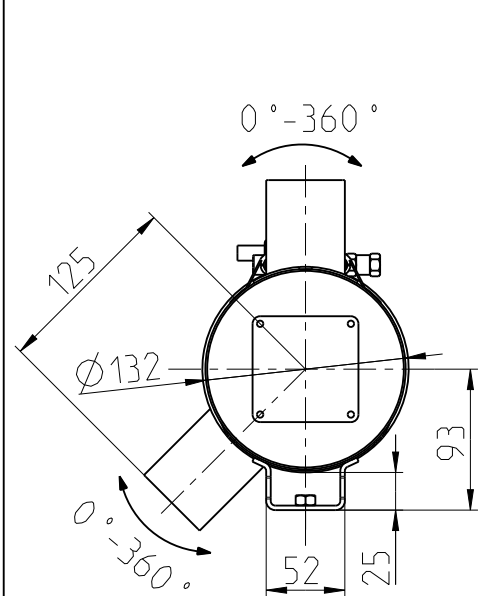

radial / radial

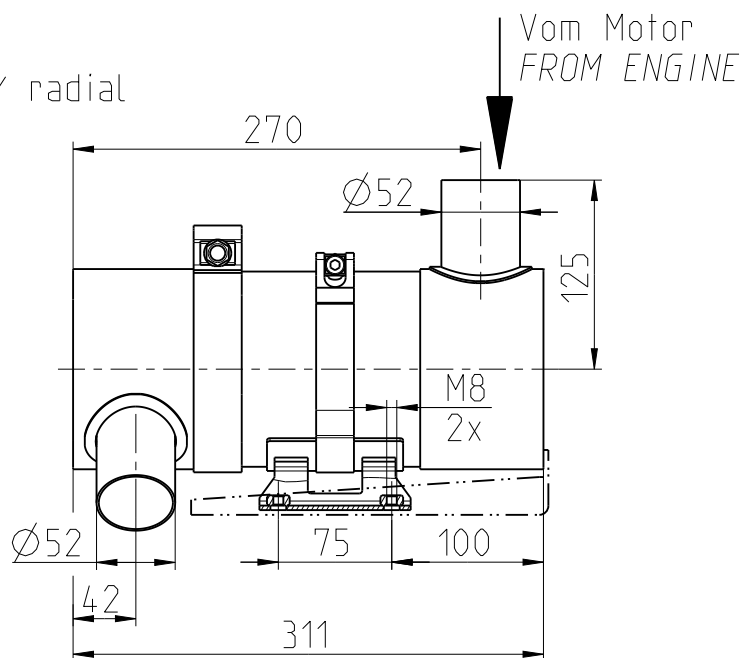

Halter DOC
HOLDING DEVICE
DOC

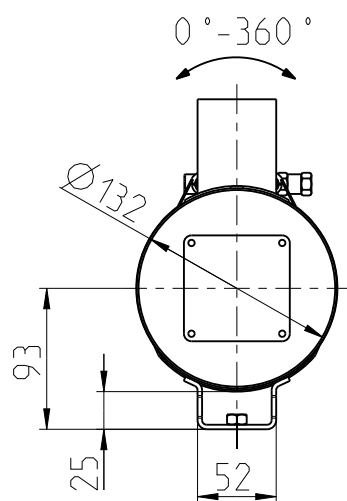
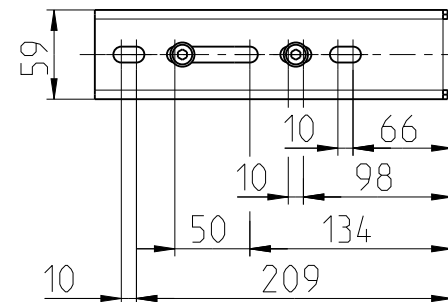

radial / axial

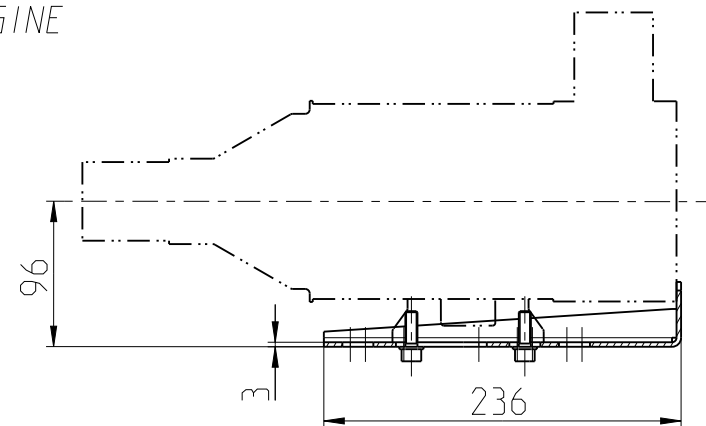
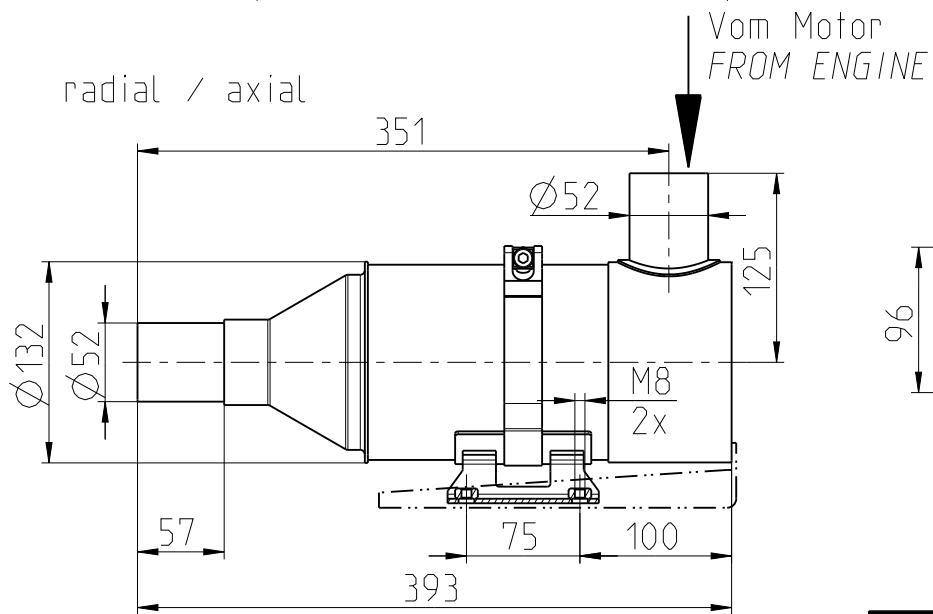

Nr.	Datum	Name	Änderung
NICHT MANUELL ÄNDERN			



INSTALLATION DRAWING

MASSTAB

EINBAUZEICHNUNG

SCALE

3H50TIC - DOC

1:4

SHEET OF SHEETS

DOC weggebaut

Blatt 17 von 28

DOC CUSTOMIZED

Aenderungen, die dem technischen Fortschritt dienen, behalten wir uns vor. / In the interests of technical progress we reserve the right to introduce modification
Toleranzbedingte Streubreite bei Kastenmaßen / The range of the length over-all based on tolerances can add up ±3mm

Schutzvermerk nach
PROTECTION MARK ACC. TO
DIN ISO 16016

Gez.	09.11.16	Mfi	Gepr.	09.11.16	Gerh
------	----------	-----	-------	----------	------

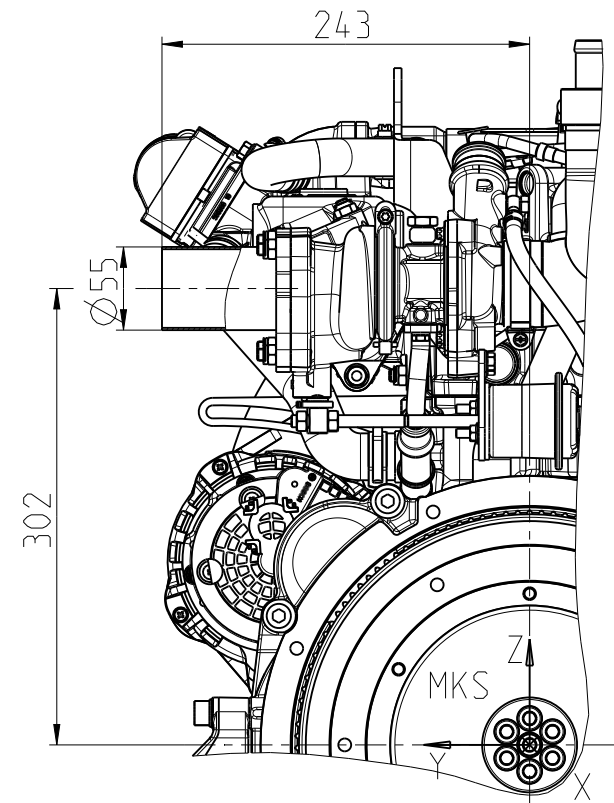
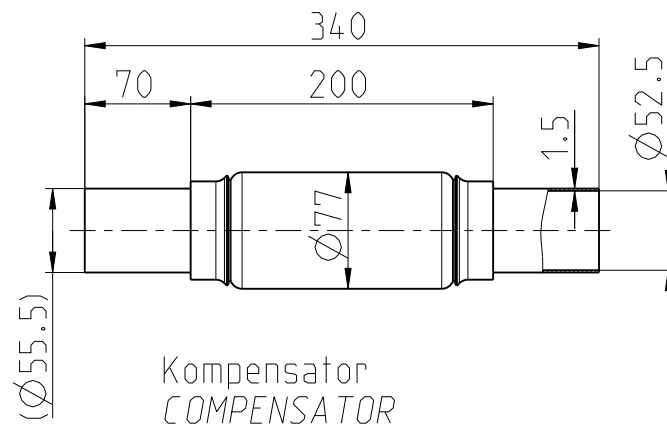
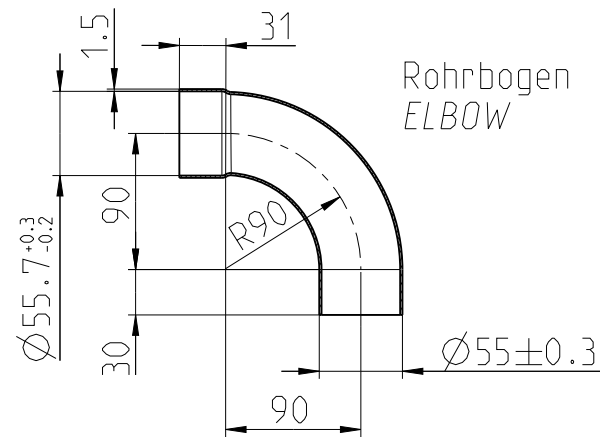
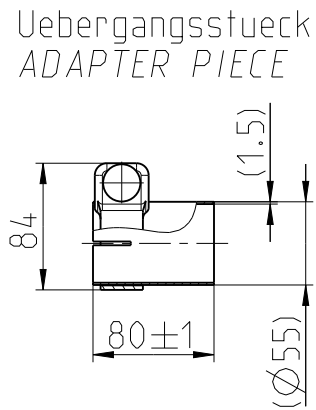
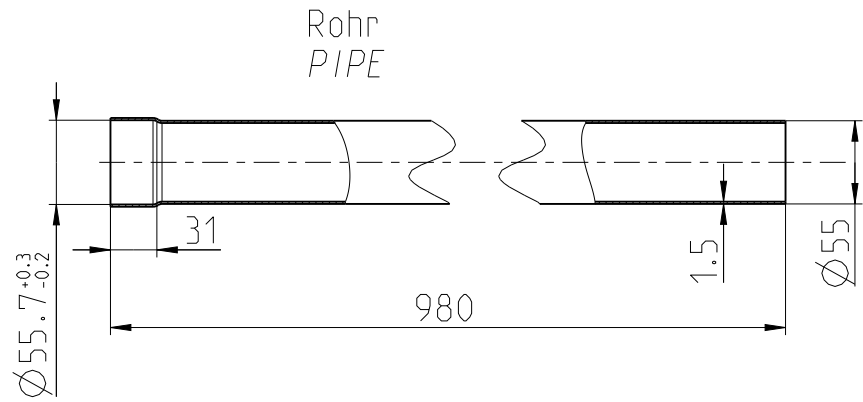

Rohrverbinder
PIPECONNECTOR
 $\varnothing 58$

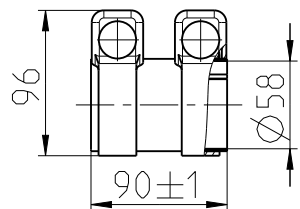

Rohrverbinder
PIPECONNECTOR
 $\varnothing 55$

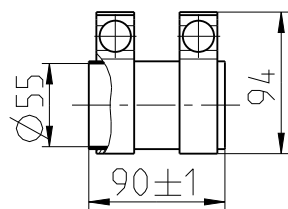

Flansch
z. Turbolader
FLANGE
Z. TURBO CHARGER

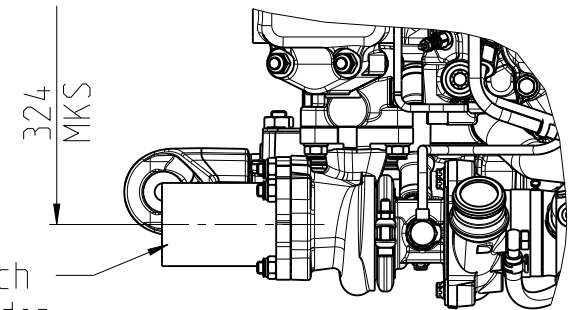

Aenderungen, die dem technischen Fortschritt dienen, behalten wir uns vor. / In the interests of technical progress we reserve the right to introduce modification
Toleranzbedingte Streubreite bei Kastenmaßen / The range of the length over-all based on tolerances can add up $\pm 3\text{mm}$

Nr.	Datum	Name	Änderung
NICHT MANUELL ÄNDERN			
Schutzvermerk nach PROTECTION MARK ACC. TO			DIN ISO 16016



INSTALLATION DRAWING EINBAUZEICHNUNG 3H50TIC		MASSTAB SCALE 1:5	
SHEET OF SHEETS Blatt 18 von 28		Abgasleitungen EXHAUST GAS PIPES	
Gez.	09.11.16	Mfi	Gepr. 09.11.16
		Gerh	

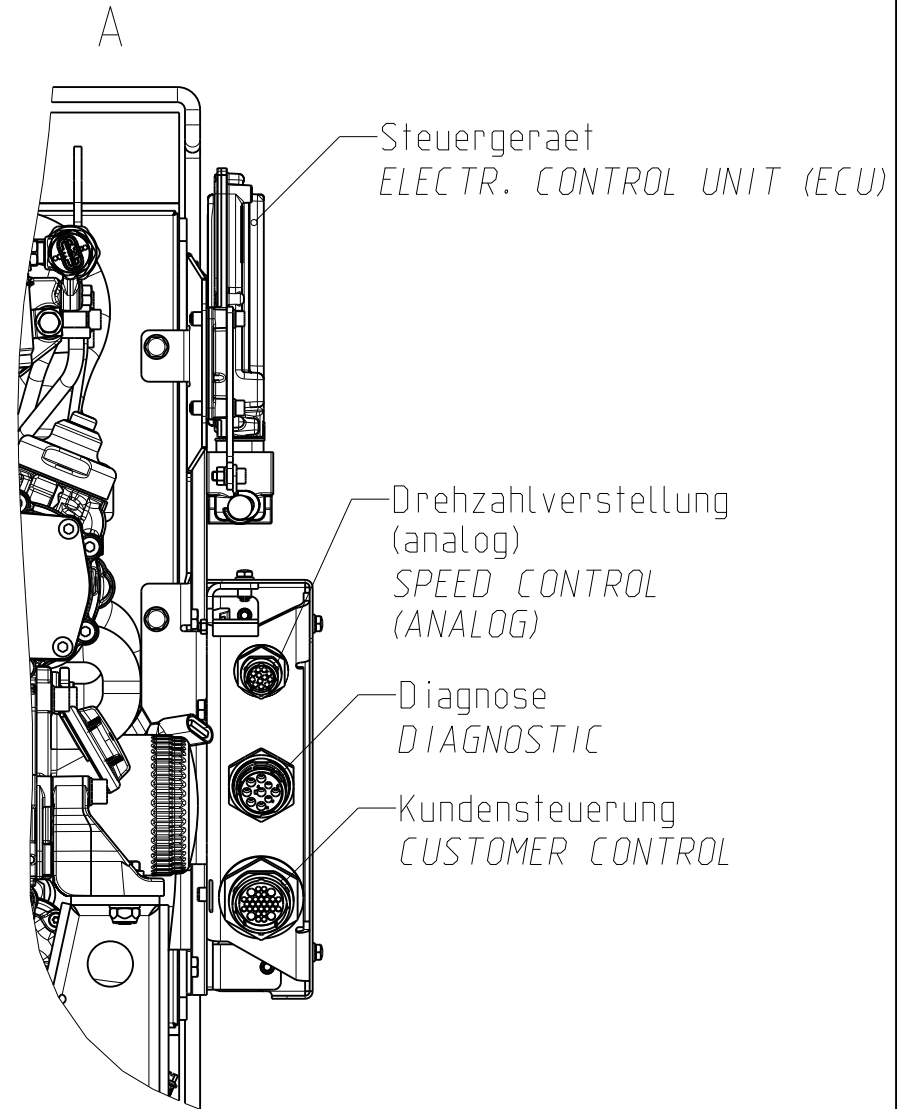
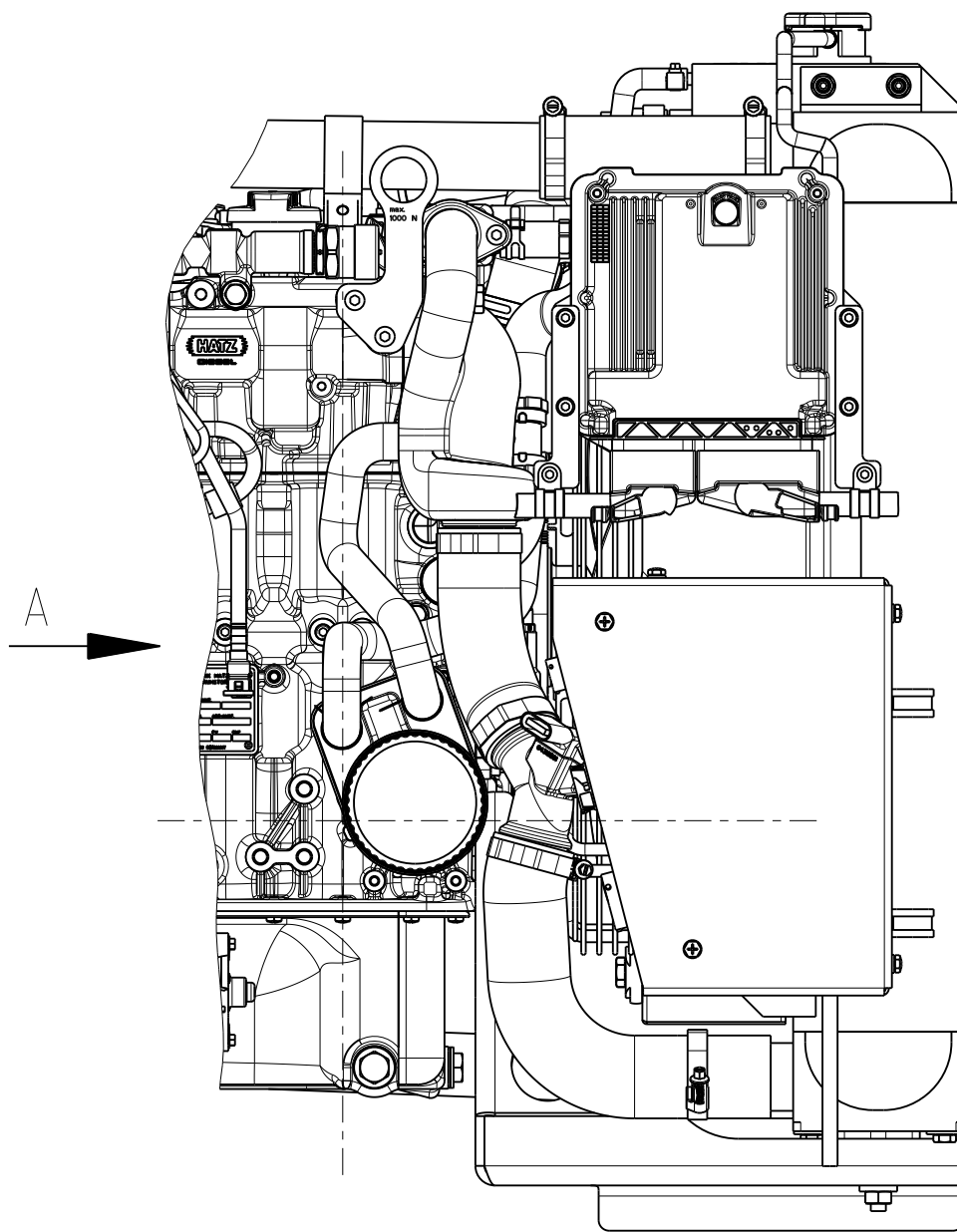

Aenderungen, die dem technischen Fortschritt dienen, behalten wir uns vor. / In the interests of technical progress we reserve the right to introduce modification

Nr.	Datum	Name	Änderung
NICHT MANUELL ÄNDERN			

Schutzvermerk nach
PROTECTION MARK ACC. TO
DIN ISO 16016



INSTALLATION DRAWING
EINBAUZEICHNUNG
3H50TIC - OPU

MASSTAB
SCALE
1:5

SHEET OF SHEETS
Blatt 19 von 28

Anschlüsse f. Steuerung
CONNECTIONS F. CONTROL

Gez.	09.11.16	Mfi	Gepr.	09.11.16	Gerh
------	----------	-----	-------	----------	------

Kraftstoffvorfilter
FUEL PRE-FILTER

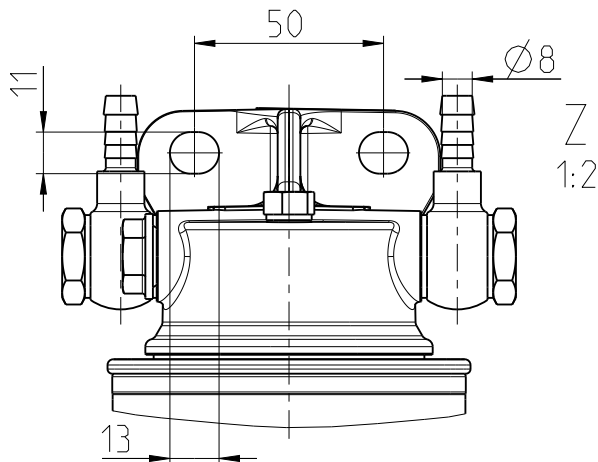
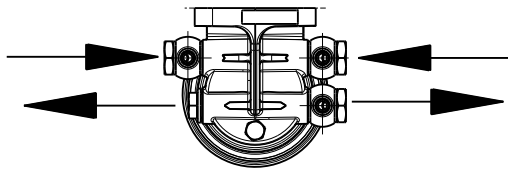
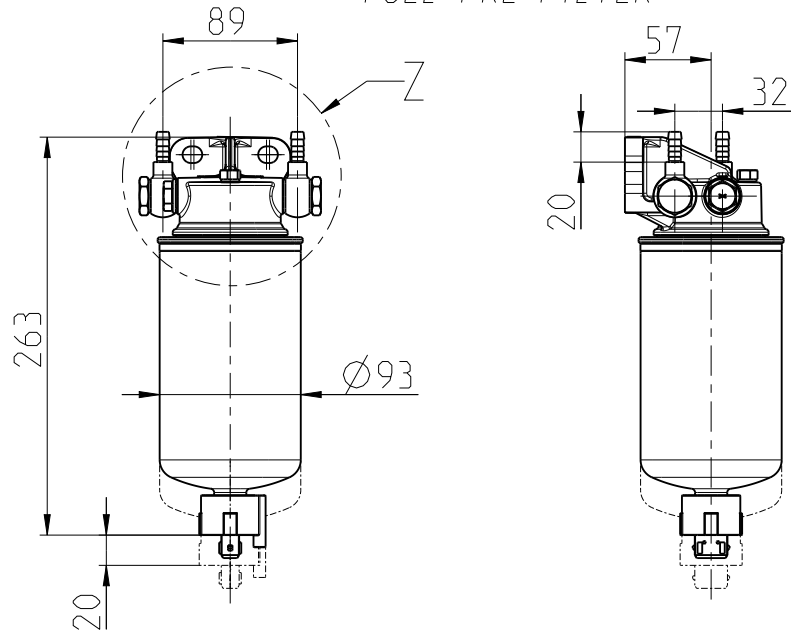

Kraftstoffhauptfilter
FUEL MAIN-FILTER

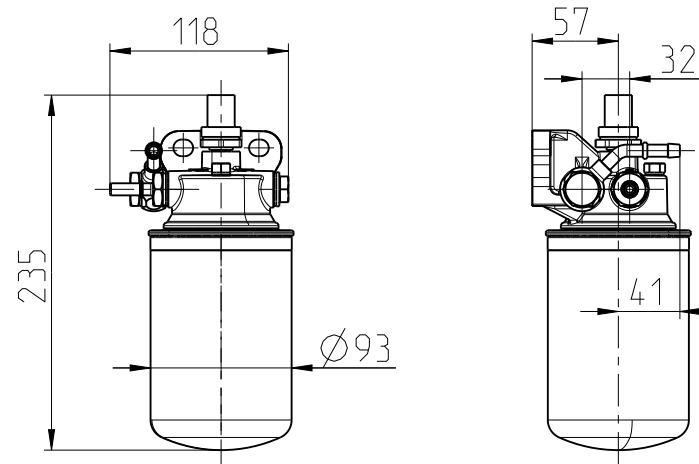

Kraftstofffoerderpumpe
FUEL DELIVERY PUMP
12V

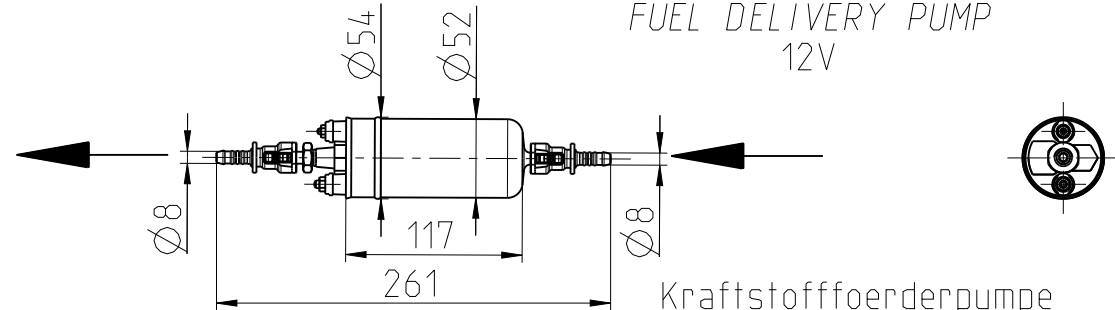

Kraftstofffoerderpumpe
FUEL DELIVERY PUMP
24V

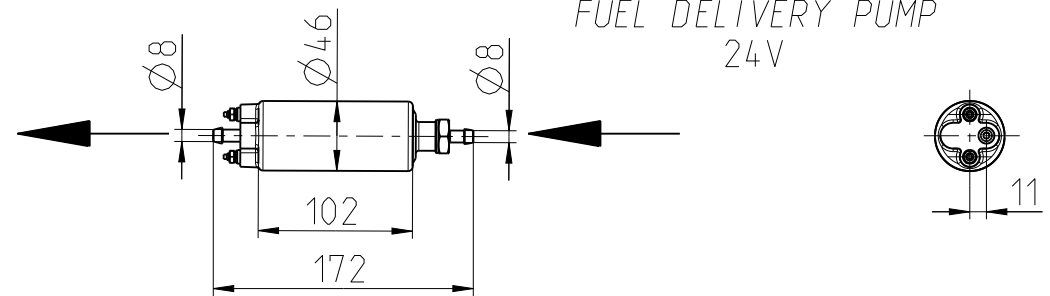

Aenderungen, die dem technischen Fortschritt dienen, behalten wir uns vor. / In the interests of technical progress we reserve the right to introduce modification
Toleranzbedingte Streubreite bei Kastenmaßen / The range of the length over-all based on tolerances can add up ±3mm

Nr.	Datum	Name	Änderung
NICHT MANUELL ÄNDERN			
Schutzvermerk nach PROTECTION MARK ACC. TO			DIN ISO 16016



INSTALLATION DRAWING		MASSTAB	
EINBAUZEICHNUNG		SCALE	
3H50TIC		1:5 (1:2)	
Kraftstoffvor-/hauptfilter-Kraftstofffoerderpumpe			
FUEL PRE-/MAIN FILTER-FUEL DELIVERY PUMP			
SHEET OF SHEETS	Blatt 20 von 28		
Gez.	09.11.16	Mfi	Gepr. 09.11.16 Gerh

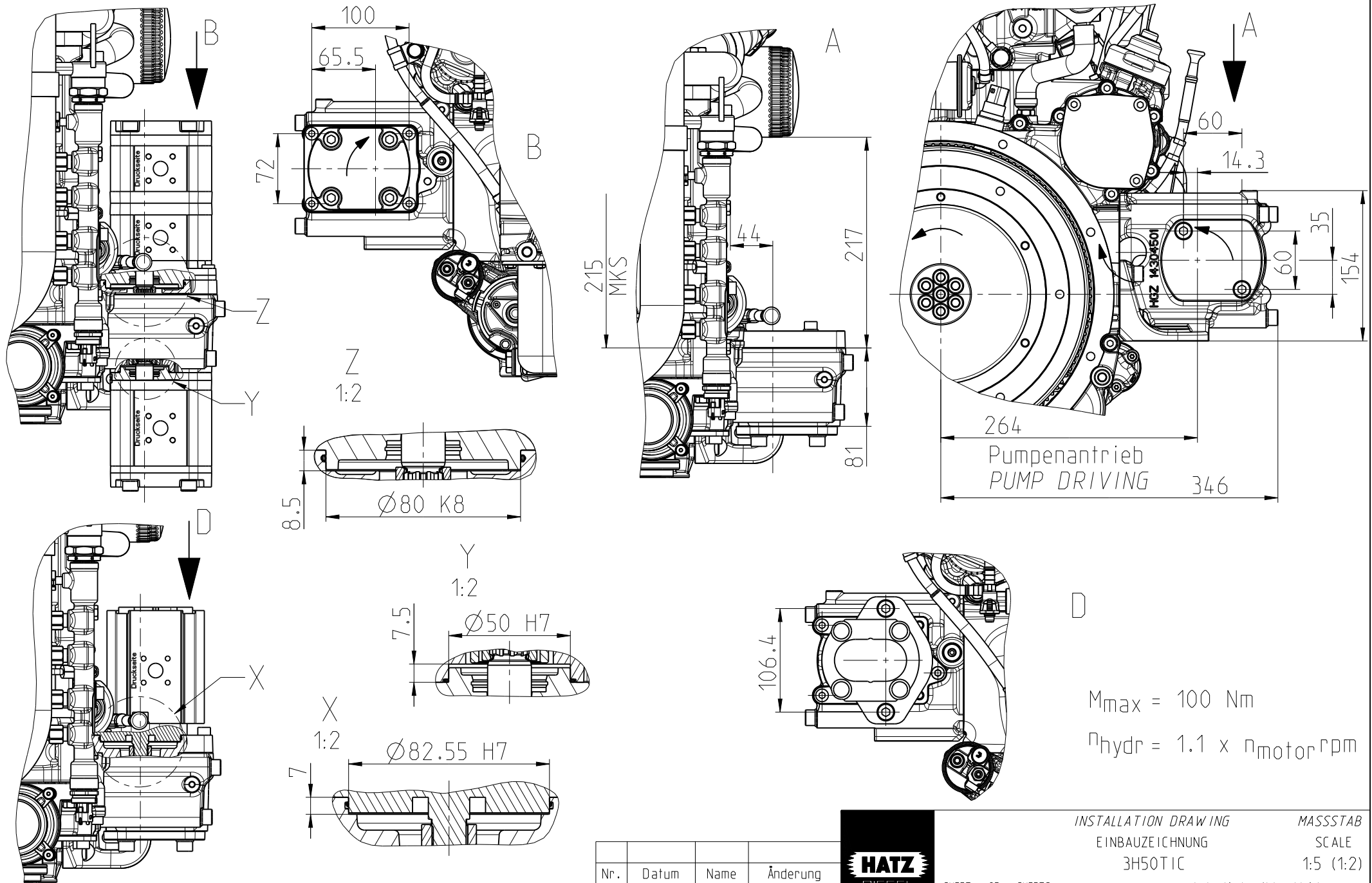

$M_{max} = 100 \text{ Nm}$
 $\eta_{hydr} = 1.1 \times \eta_{motor} \cdot \eta_{PM}$

Änderungen, die dem technischen Fortschritt dienen, behalten wir uns vor. / In the interests of technical progress we reserve the right to introduce modification
 Toleranzbedingte Streubreite bei Kastenmaßen / The range of the length over-all based on tolerances can add up $\pm 3\text{mm}$

Nr.	Datum	Name	Änderung
NICHT MANUELL ÄNDERN			
			Schutzvermerk nach PROTECTION MARK ACC. TO
			DIN ISO 16016



INSTALLATION DRAWING EINBAUZEICHNUNG 3H50TIC		MASSTAB SCALE 1:5 (1:2)	
SHEET OF SHEETS Blatt 21 von 28		hydraulischer Nebenantrieb HYDRAULIC SIDE PTO	
Gez.	09.11.16	Mfi	Gepr. 09.11.16
		Gerh	

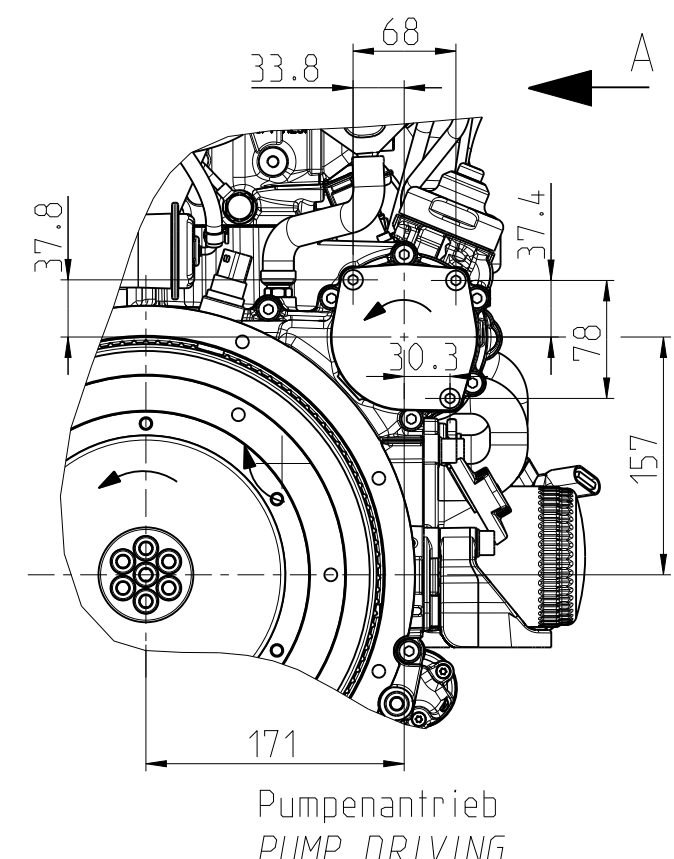
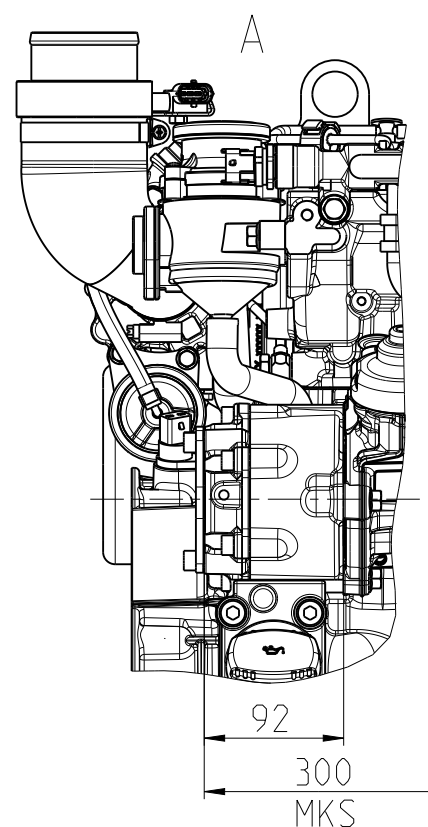
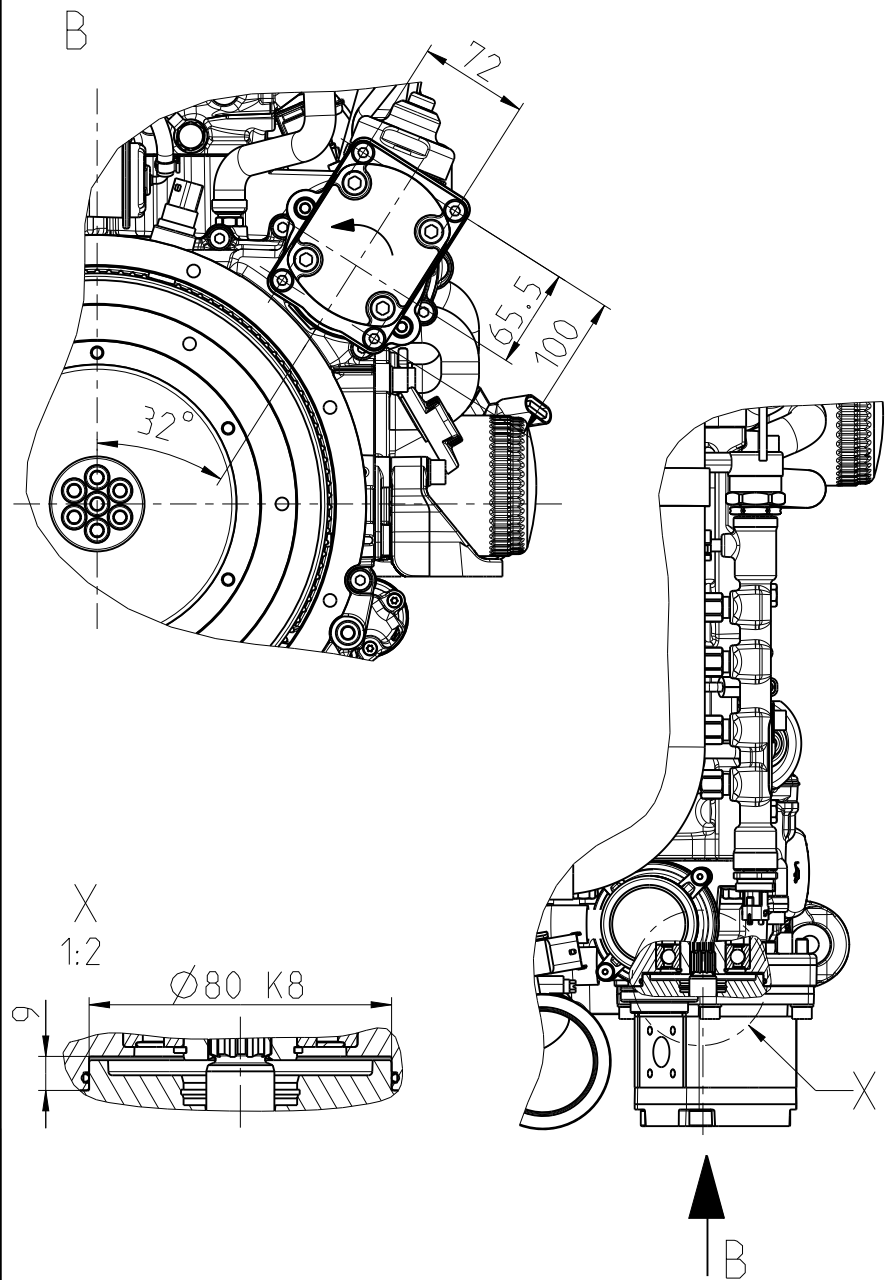

Änderungen, die dem technischen Fortschritt dienen, behalten wir uns vor. / In the interests of technical progress we reserve the right to introduce modification Toleranzbedingte Streubreite bei Kastenmaßen / The range of the length over-all based on tolerances can add up $\pm 3\text{mm}$					INSTALLATION DRAWING EINBAUZEICHNUNG 3H50TIC - F2F		MASSSTAB SCALE 1:5 (1:2)	
Nr. Datum Name Änderung NICHT MANUELL ÄNDERN					MOTORENFABRIK HATZ RUHSTORF-ROTT		SHEET OF SHEETS Blatt 22 von 28 Gez. 09.11.16 Mfi Gepr. 09.11.16 Gerh	
Schutzvermerk nach PROTECTION MARK ACC. TO				DIN ISO 16016		hydraulischer Frontantrieb HYDRAULIC FRONT PTO		

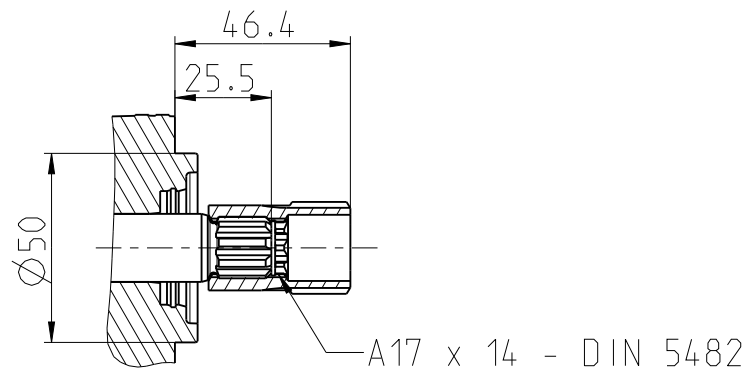

A17 x 14 - DIN 5482

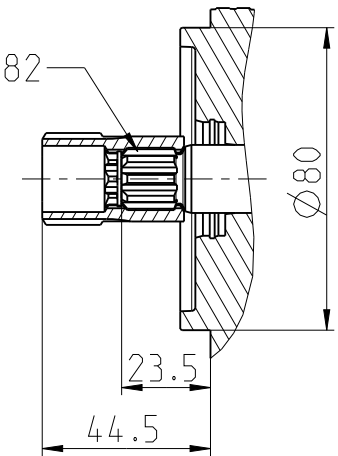

SAE J 744 16-4 9T 16/32DP

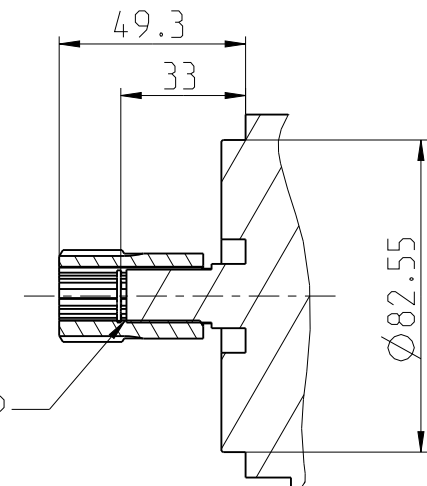

Nr.	Datum	Name	Änderung
NICHT MANUELL ÄNDERN			



INSTALLATION DRAWING

MASSTAB

EINBAUZEICHNUNG

SCALE

3H501C

1:2

SHEET OF SHEETS

Mitnehmer zum hydr. Nebenantrieb

Blatt 23 von 28

SPLINED COUPLING TO HYDR SIDE PTO

Aenderungen, die dem technischen Fortschritt dienen, behalten wir uns vor. / In the interests of technical progress we reserve the right to introduce modification

Schutzvermerk nach

DIN ISO 16016

Toleranzbedingte Streubreite bei Kastenmaßen / The range of the length over-all based on tolerances can add up ±3mm

PROTECTION MARK ACC. TO

Gez.	09.11.16	Mfi	Gepr.	09.11.16	Gerh
------	----------	-----	-------	----------	------

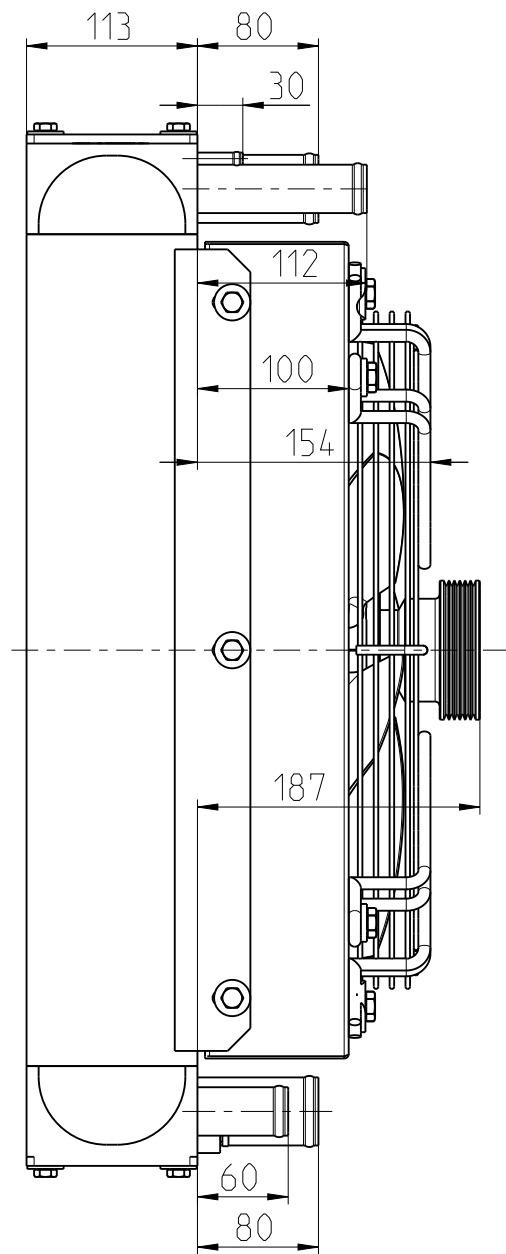
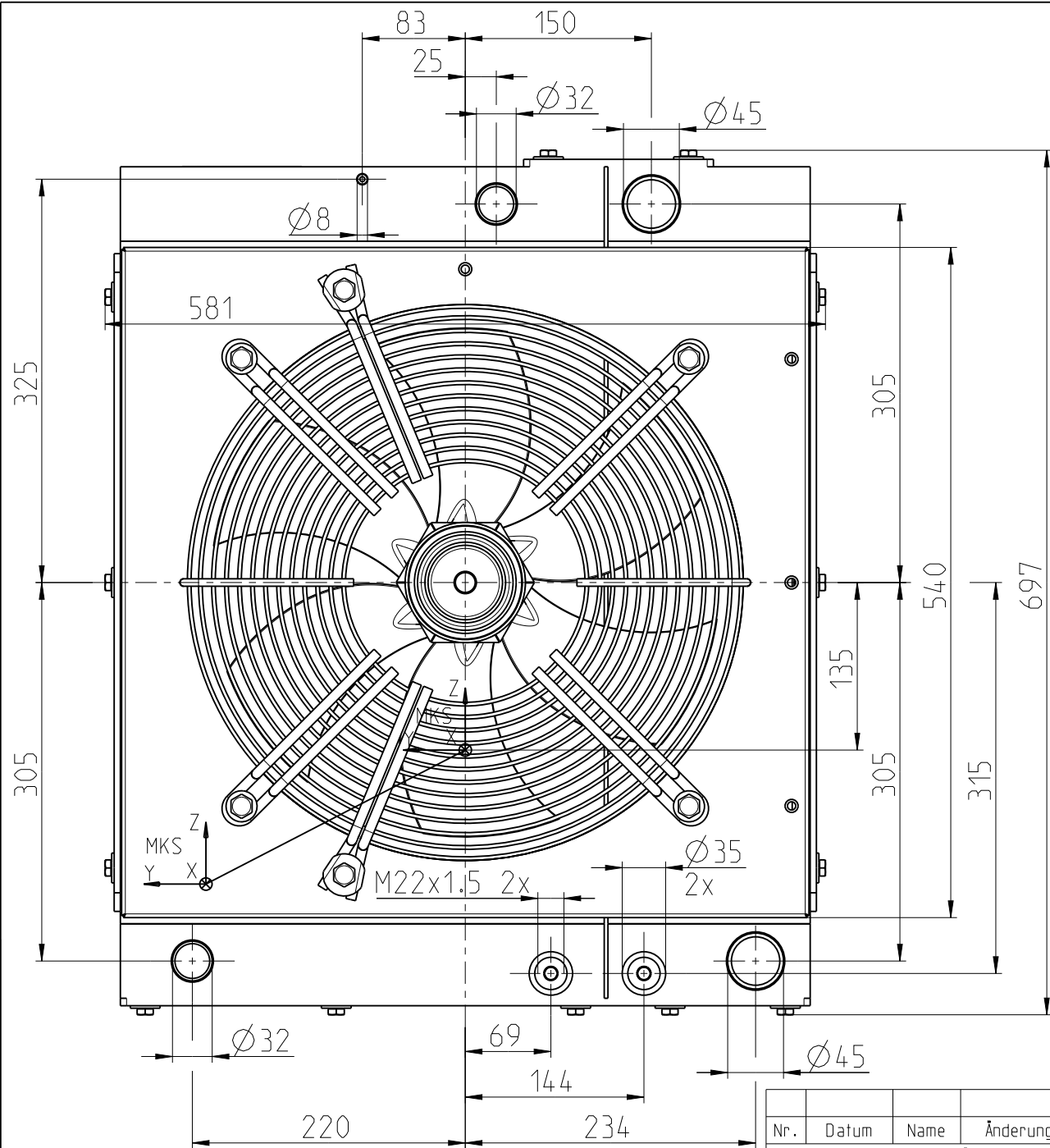

Aenderungen, die dem technischen Fortschritt dienen, behalten wir uns vor. / In the interests of technical progress we reserve the right to introduce modification
 Toleranzbedingte Streubreite bei Kastenmaßen / The range of the length over-all based on tolerances can add up $\pm 3\text{mm}$

Nr.	Datum	Name	Änderung
NICHT MANUELL ÄNDERN			

Schutzvermerk nach
 PROTECTION MARK ACC. TO
 DIN ISO 16016



INSTALLATION DRAWING
 EINBAUZEICHNUNG
 3H50TIC - F2F
 MASSTAB
 SCALE
 1:5

SHEET OF SHEETS
 F2F Kombikuehler f. ext. Ausgleichsbehälter
 Blatt 24 von 28 F2F RADIATOR AIR+WATER F.EXT. EXPANS.TANK
 Gez. 09.11.16 Mfi Gepr. 09.11.16 Gerh

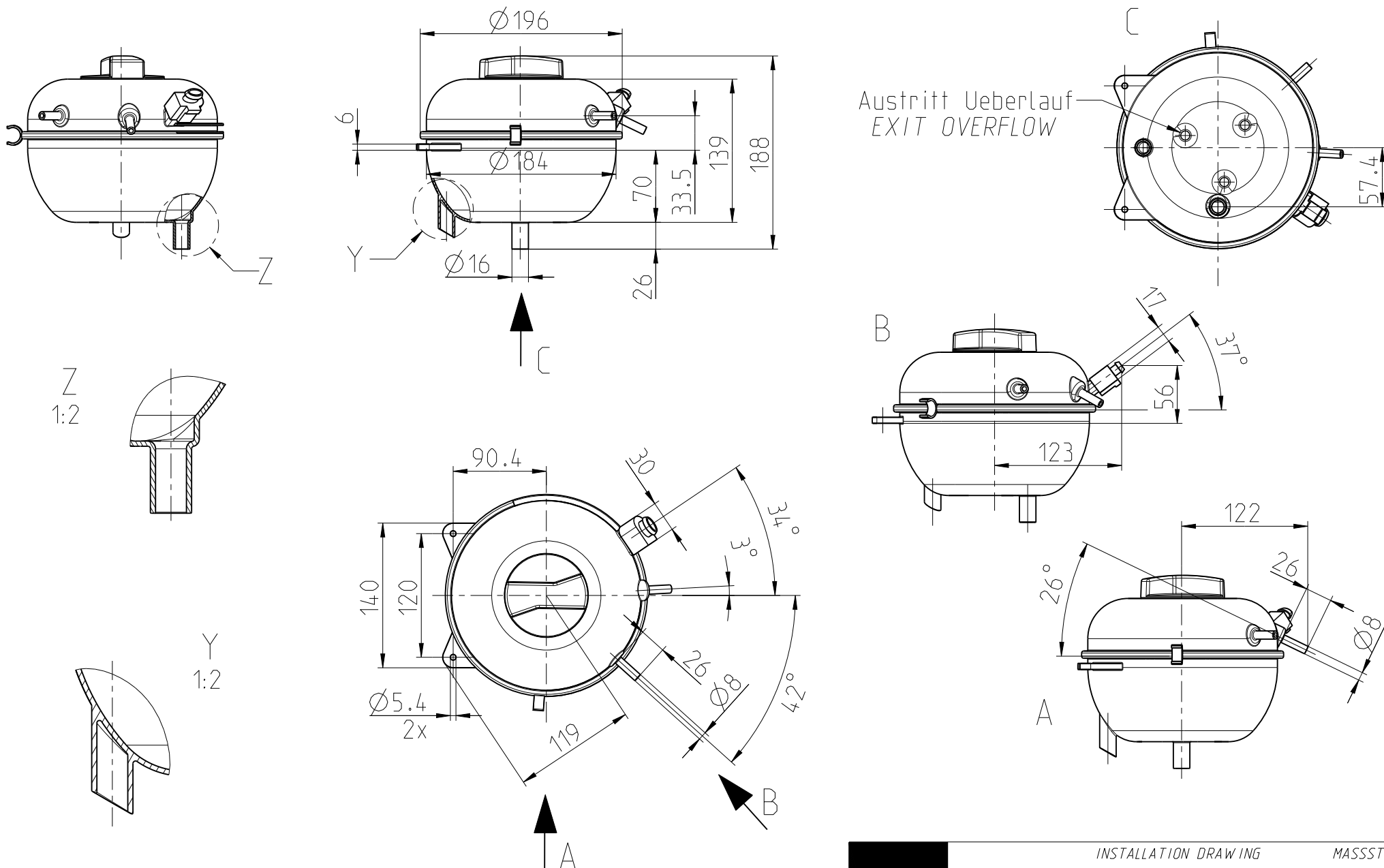

Aenderungen, die dem technischen Fortschritt dienen, behalten wir uns vor. / In the interests of technical progress we reserve the right to introduce modification
Toleranzbedingte Streubreite bei Kastenmaßen / The range of the length over-all based on tolerances can add up $\pm 3\text{mm}$

Nr.	Datum	Name	Änderung
NICHT MANUELL ÄNDERN			

Schutzvermerk nach
PROTECTION MARK ACC. TO
DIN ISO 16016



INSTALLATION DRAWING		MASSTAB	
EINBAUZEICHNUNG		SCALE	
3H50TIC - F2F		1:5 (1:2)	
SHEET OF SHEETS		externer Ausgleichsbehälter	
Blatt 25 von 28		EXTERNAL EXPANSION TANK	
Gez.	09.11.16	Mfi	Gepr. 09.11.16
		Gerh	

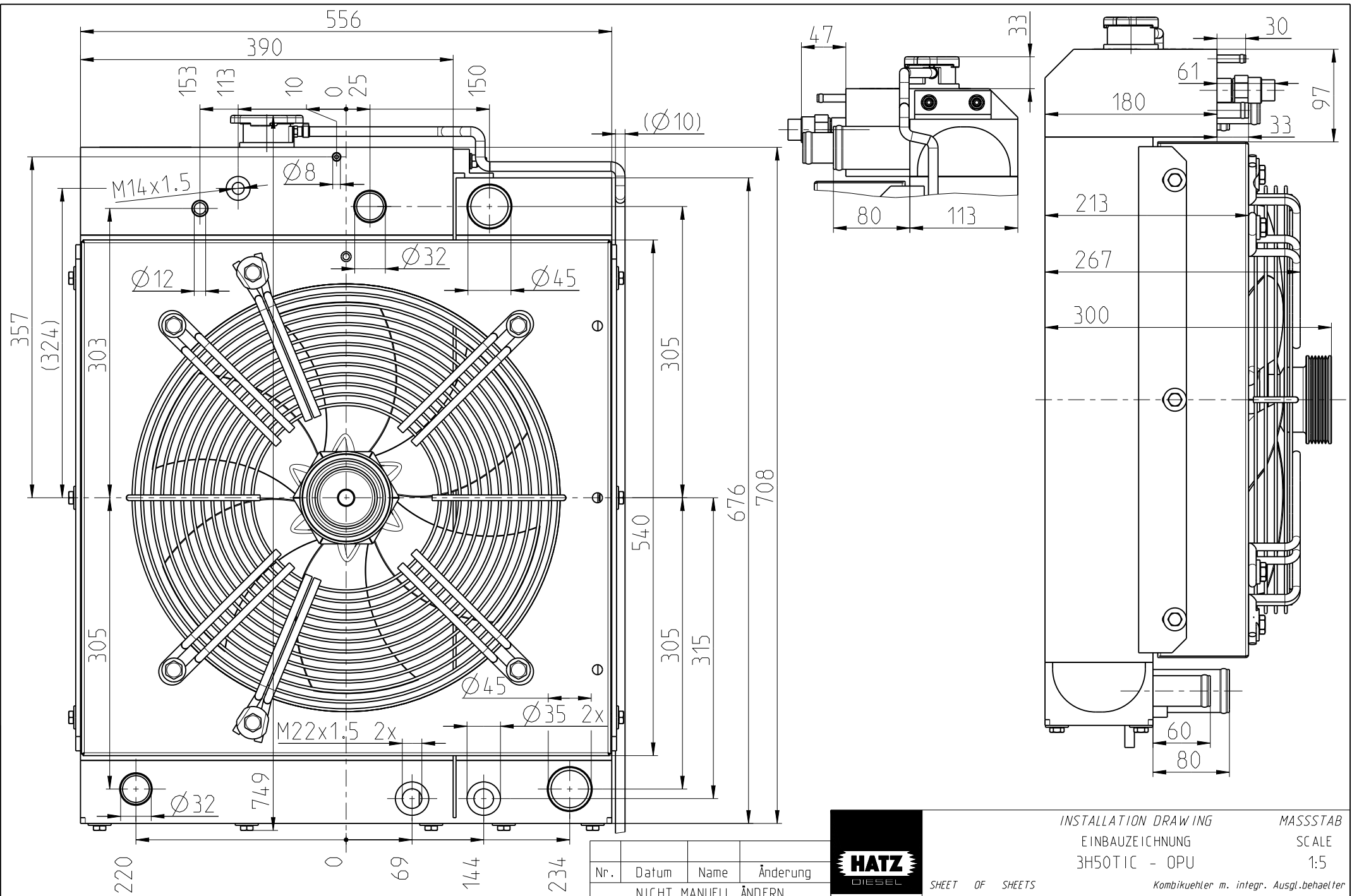

Aenderungen, die dem technischen Fortschritt dienen, behalten wir uns vor. / In the interests of technical progress we reserve the right to introduce modification
 Toleranzbedingte Streubreite bei Kastenmaßen / The range of the length over-all based on tolerances can add up ±3mm

Nr.	Datum	Name	Änderung
NICHT MANUELL ÄNDERN			
Schutzvermerk nach			DIN ISO 16016
PROTECTION MARK ACC. TO			

HATZ
DIESEL
MOTORENFABRIK
HATZ
RUHSTORF-ROTT

INSTALLATION DRAWING
 EINBAUZEICHNUNG
 3H50TIC - OPU
 SHEET OF SHEETS
 Blatt 26 von 28 RADIATOR AIR+WATER W. INTEGR. EXPANS.TANK
 Gez. 09.11.16 Mfi Gepr. 09.11.16 Gerh
 MASSTAB
 SCALE
 1:5
 Kombikuehler m. integr. Ausgl.behaelter

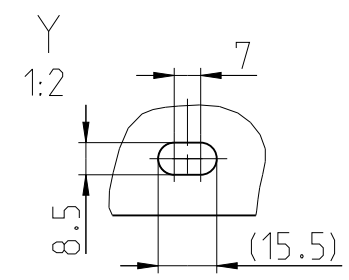
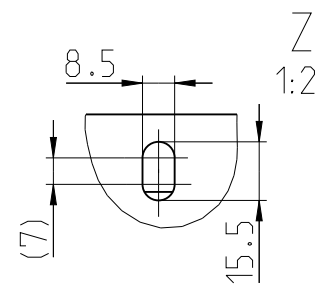
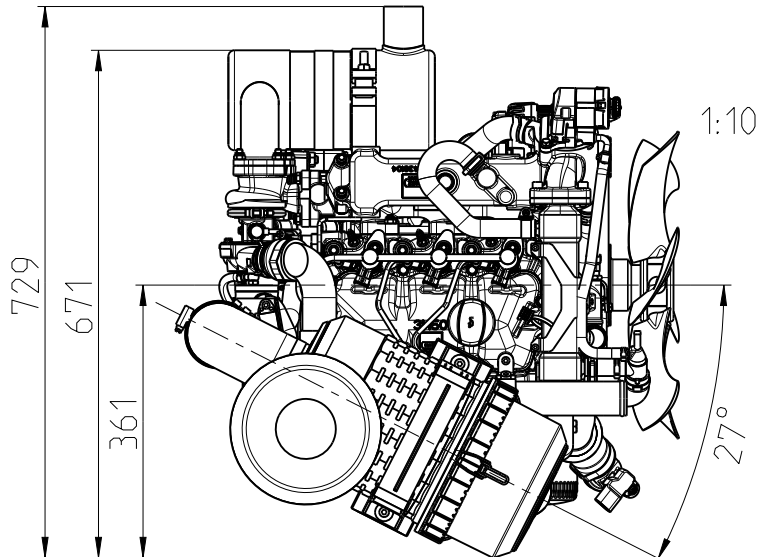
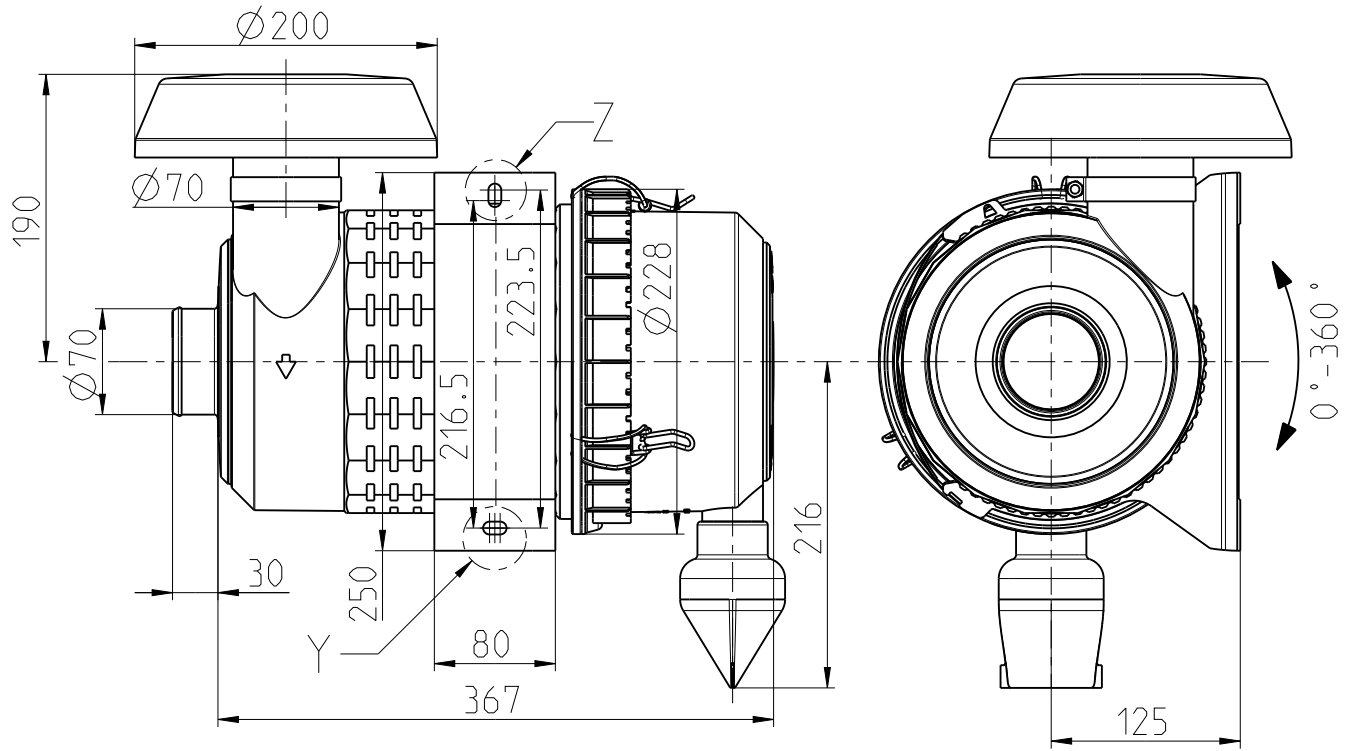
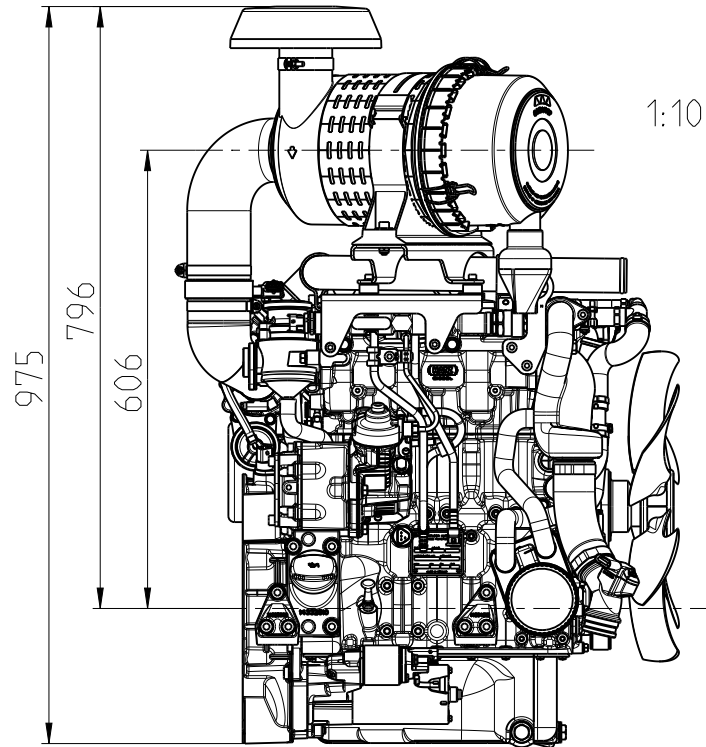

Nr.	Datum	Name	Änderung
NICHT MANUELL ÄNDERN			



INSTALLATION DRAWING EINBAUZEICHNUNG 3H50TIC		MASSTAB SCALE 1:5 (1:10;1:2)	
SHEET OF SHEETS Blatt 27 von 28		Luftfilter AIR FILTER	
Gez.	09.11.16	Mfi	Gepr. 09.11.16
		Gerh	

Aenderungen, die dem technischen Fortschritt dienen, behalten wir uns vor. / In the interests of technical progress we reserve the right to introduce modification
 Toleranzbedingte Streubreite bei Kastenmaßen / The range of the length over-all based on tolerances can add up ±3mm

Schutzvermerk nach
PROTECTION MARK ACC. TO
DIN ISO 16016

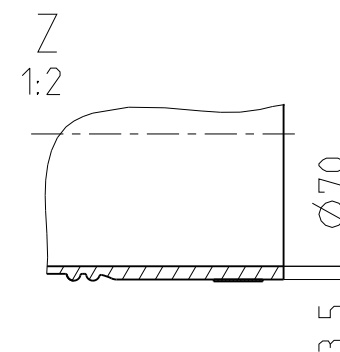
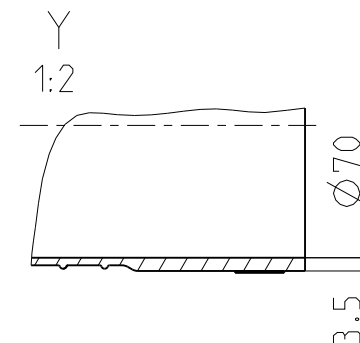
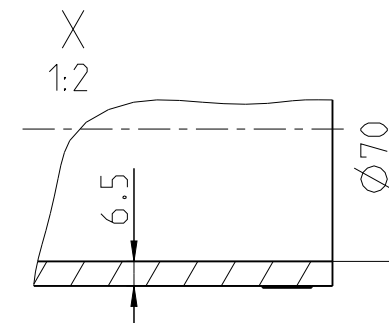
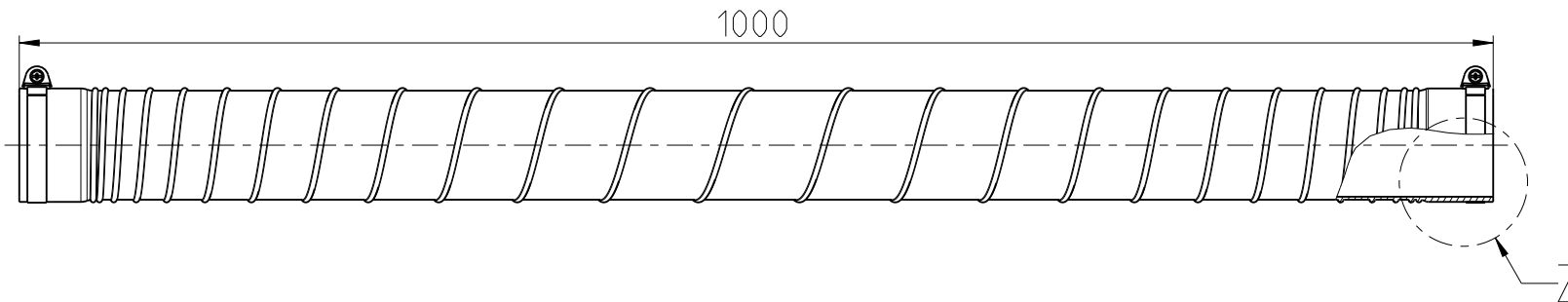
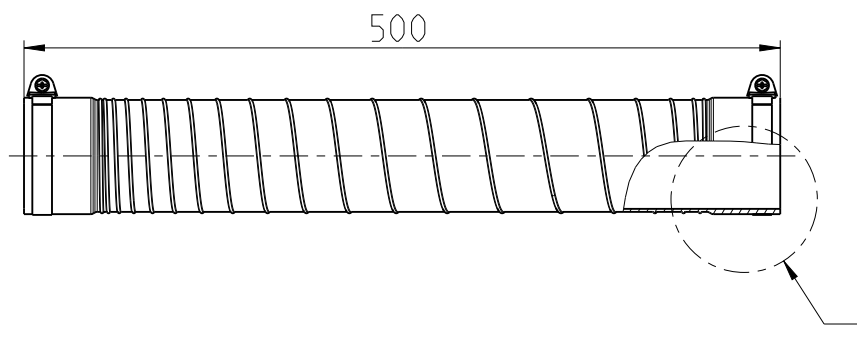
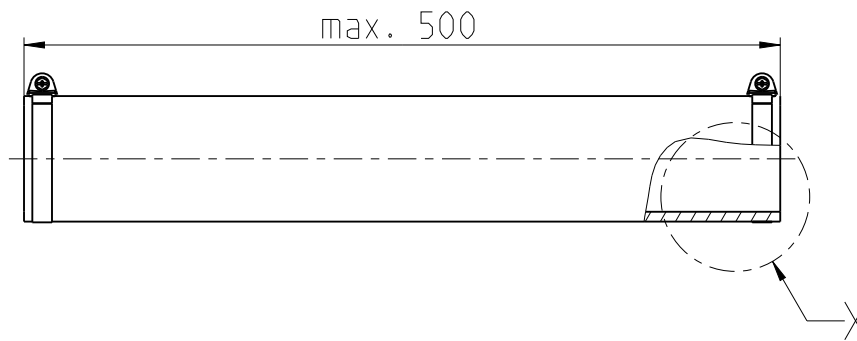
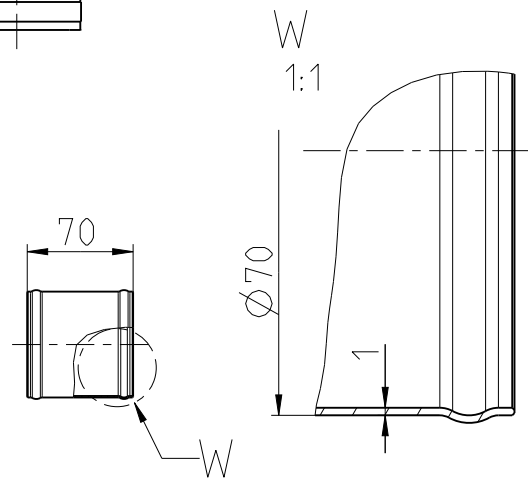
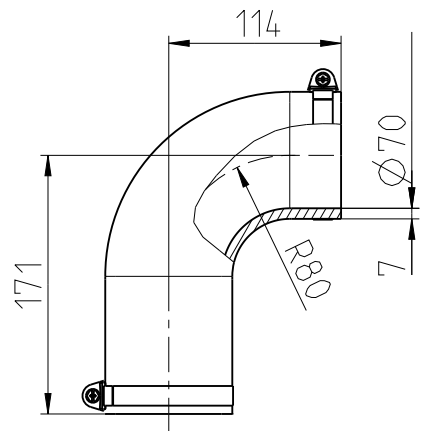

Aenderungen, die dem technischen Fortschritt dienen, behalten wir uns vor. / In the interests of technical progress we reserve the right to introduce modification
 Toleranzbedingte Streubreite bei Kastenmaßen / The range of the length over-all based on tolerances can add up ±3mm

Nr.	Datum	Name	Änderung
NICHT MANUELL ÄNDERN			
Schutzvermerk nach			DIN ISO 16016
PROTECTION MARK ACC. TO			



INSTALLATION DRAWING MASSSTAB
 EINBAUZEICHNUNG SCALE
 3H50TIC 1:5 (1:2;1:1)

Verschlauchung Luftfilter
 HOSE LINES FOR AIR FILTER

SHEET OF SHEETS
 Blatt 28 von 28

Gez.	09.11.16	Mfi	Gepr.	09.11.16	Gerh
------	----------	-----	-------	----------	------